

Installation manual

Terra HP Generation 3 CE 175 kW Static DC system

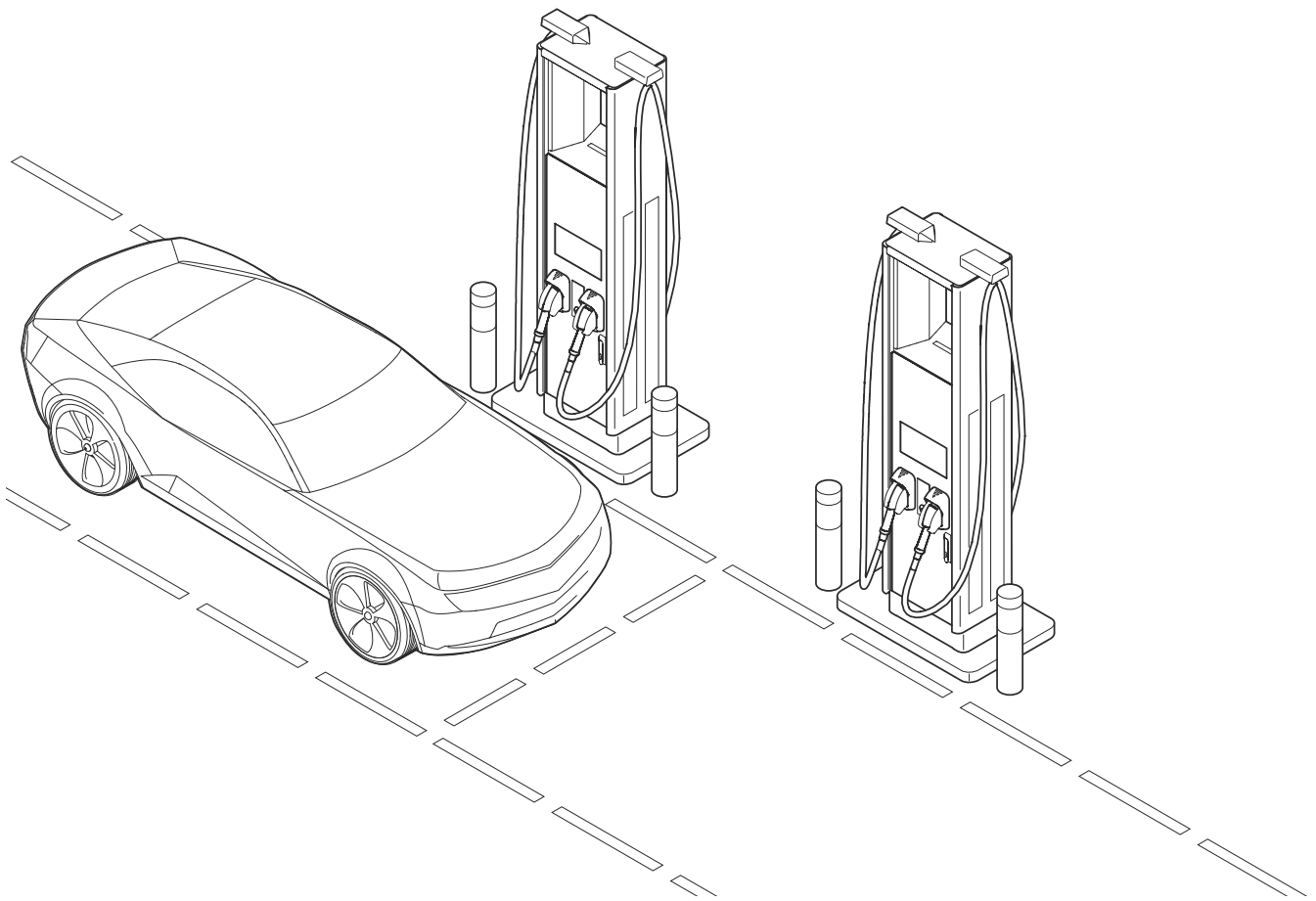

Copyright

All rights to copyrights, registered trademarks, and trademarks reside with their respective owners.

Copyright © ABB E-Mobility B.V.. All rights reserved.

Contents

1	About this document.....	8
1.1	Function of this document.....	8
1.2	Target group.....	8
1.3	Revision history.....	8
1.4	Language.....	8
1.5	Illustrations.....	8
1.6	Units of measurement.....	8
1.7	Typographical conventions.....	8
1.8	How to use this document.....	9
1.9	General symbols and signal words.....	9
1.10	Special symbols for warnings and dangers.....	10
1.11	Colors of lines in schematic drawings.....	10
1.12	Related documents.....	11
1.13	Manufacturer and contact data.....	11
1.14	Abbreviations.....	11
1.15	Terminology.....	12
1.16	Orientation agreements.....	13
2	Safety.....	14
2.1	Liability.....	14
2.2	General safety instructions.....	14
2.3	Required qualifications for the installation person.....	15
2.4	Personal protective equipment.....	15
2.5	Safety instructions during transport.....	15
2.6	Safety instructions during installation.....	16
2.7	Safety instructions for earthing.....	16
2.8	Signs on the EVSE.....	17
2.9	Identifier labels on the EVSE (EN 17186 norm).....	17
2.10	Discard the EVSE or parts of the EVSE.....	18
2.11	Cyber security.....	19
3	Description.....	20
3.1	Intended use.....	20
3.2	Type plate.....	20
3.3	General description of the EVSE.....	21
3.4	Working principle.....	21
3.5	Overview and functions.....	22
3.5.1	Power cabinet, outside.....	22
3.5.2	Power cabinet, inside.....	23

3.5.3	DC output busbar in a static DC system.....	24
3.5.4	Charge post CP500 Generation 3, outside.....	24
3.5.5	Charge post CP500 Generation 3, inside.....	25
3.5.6	Overview of the cable glands of the charge post.....	26
3.6	External residual-current device.....	26
3.7	Options.....	27
3.7.1	Tilt sensors.....	27
4	Pre-installation.....	28
4.1	Pre-installation procedure (site planning).....	28
4.2	Prepare the site.....	28
4.3	Make sure that the floor space for the EVSE and the airflow around the EVSE is correct.....	29
4.4	Prepare the foundation.....	29
4.4.1	Prepare the foundation - general procedure.....	29
4.4.2	Prepare a prefab concrete foundation for the power cabinet.....	29
4.4.3	Prepare a custom foundation for the power cabinet.....	30
4.4.4	Prepare a prefab concrete foundation for the charge post.....	31
4.4.5	Prepare a custom foundation for the charge post.....	31
5	Inspection and transport.....	32
5.1	Transport the EVSE to the site.....	32
5.2	Inspect the EVSE on delivery.....	32
5.3	Do a check of the transport sensors.....	33
5.4	Unpack the EVSE.....	33
5.5	Transport the EVSE on the site.....	33
5.5.1	General transport procedure.....	33
5.5.2	Tilt the charge post to the vertical position.....	34
5.5.3	Move the cabinet with a forklift truck.....	35
5.5.4	Hoist the cabinet.....	35
5.6	Remove the cabinet from the pallet.....	36
6	Installation.....	37
6.1	General installation procedure.....	37
6.2	Mechanical installation of the power cabinet.....	37
6.2.1	Install the power cabinet - general procedure.....	37
6.2.2	Install the cabinet on the foundation.....	38
6.2.3	Open the cable inlets	38
6.2.4	Guide the cables to the cabinet.....	38
6.2.5	Close the cable inlets	39
6.2.6	Install the front cover plate (concrete foundation).....	39
6.3	Mechanical installation of the charge post.....	40
6.3.1	Install the charge post - general procedure.....	40

6.3.2	Remove the cable gland plates.....	41
6.3.3	Install the charge post on the foundation.....	41
6.3.4	Install the cable gland plates.....	42
7	Electrical installation of the power cabinet.....	43
7.1	General procedure.....	43
7.2	Connect the PE cables to the power cabinet.....	43
7.3	Connect the DC power cables, static 175 kW system.....	44
7.4	Connect the AC input cable.....	45
7.5	Connect the AC auxiliary power cable in the power cabinet.....	46
7.6	Connect the interlock and DC guard cables to the power cabinet.....	47
7.7	Connect the optical CAN cables from the charge post to the power cabinet.....	48
7.8	Connect the control cable for the tilt sensors to the power cabinet (option).....	49
8	Electrical installation of the charge post.....	50
8.1	General procedure.....	50
8.2	Connect the PE wire.....	50
8.3	Connect the DC power input cables.....	51
8.4	Connect the AC auxiliary power cable.....	52
8.5	Connect the interlock and DC guard cable.....	52
8.6	Connect the optical CAN cable.....	53
8.7	Connect the Ethernet cable.....	54
8.8	Connect the control cable for the tilt sensors from the external customer interface to the charge post (option).....	55
9	Prepare for commissioning.....	56
10	Access to parts.....	57
10.1	Open the door of the power cabinet.....	57
10.2	Remove the plinth covers of the power cabinet.....	57
10.3	Remove the DC busbar cover.....	58
10.4	Remove the AC covers.....	58
10.5	Close the door of the power cabinet.....	59
10.6	Open the door of the charge post.....	60
10.7	Remove the plinth covers of the charge post.....	60
10.8	Remove the protection plate of the charge post.....	61
10.9	Close the door of the charge post.....	61
11	Generic procedures.....	63
11.1	Install a cable lug on a wire.....	63
11.2	Install a ferrule on a wire.....	63
11.3	Install insulating heatshrink tubing on a wire.....	64

11.4 Connect a wire that has a cable lug..... 65
 11.5 Connect a wire that has a ferrule..... 65

12 Technical data..... 66

12.1 EVSE type..... 66
 12.2 Parts included in the delivery..... 66
 12.3 Required tools for installation..... 67
 12.4 Required parts for installation..... 67
 12.5 Transport specifications..... 68
 12.6 General specifications..... 68
 12.7 Electrical installation specifications (Europe)..... 69
 12.8 Input current unbalance..... 70
 12.9 DC output specifications..... 71
 12.10 Logic interfaces specifications..... 71
 12.11 Current peaks during the start of a charge session (DC output)..... 71
 12.12 Mass and center of gravity..... 71
 12.12.1 Mass..... 71
 12.12.2 Center of gravity, power cabinet..... 72
 12.12.3 Center of gravity, charge post..... 73
 12.13 Tilt sensor specifications (option)..... 73
 12.14 Ambient conditions..... 73
 12.15 Noise level..... 74
 12.16 Torque specifications..... 74
 12.17 Dimensions..... 75
 12.17.1 Power cabinet..... 75
 12.17.2 Charge post..... 75
 12.17.3 Height of user operable elements..... 76
 12.18 Space requirements..... 77
 12.18.1 Power cabinet..... 77
 12.18.2 Charge post..... 79
 12.18.3 Charge post: exceptions for bollards and other minor fixed obstacles..... 80
 12.18.4 Distance requirements between power cabinet and charge post..... 81
 12.19 Foundation specifications..... 81
 12.19.1 Power cabinet (prefab concrete)..... 81
 12.19.2 Power cabinet (custom)..... 85
 12.19.3 Charge post (prefab concrete)..... 87
 12.19.4 Charge post (custom)..... 89
 12.20 Overview of the cable conduits..... 90
 12.21 Cable specifications..... 91
 12.21.1 AC input cable for the power cabinet..... 91
 12.21.2 DC power installation cables 91
 12.21.3 PE cable..... 92
 12.21.4 AC auxiliary power cables..... 93
 12.21.5 Interlock and DC guard cables..... 93

12.21.6	Optical CAN cables between the power cabinet and the charge post.....	93
12.21.7	Cable for the tilt sensor control.....	94
12.21.8	Ethernet cable.....	94
12.22	AC input connection configuration.....	94
12.23	Electrical connection diagram.....	97
13	Appendix.....	98
13.1	Messrichtigkeitshinweise gemäß Baumusterprüfbescheinigung.....	98

1 About this document

1.1 Function of this document

The document is only applicable for this EVSE: Terra HP Generation 3, including the variants and options listed in section 12.1.
The document gives the information that is necessary to install the EVSE.

1.2 Target group

The document is intended for qualified installation persons.
For a description of the required qualifications, refer to section 2.3.

1.3 Revision history

Version	Date	Description
001	March 2021	Initial version
002	May 2021	Updates
003	July 2021	Updates
004	November 2021	Updates
005	April 2022	Change of company name and address
006	June 2023	Updates
007	December 2023	Updates

1.4 Language

The original instructions of this document are in English (EN-US). All other language versions are translations of the original instructions.

1.5 Illustrations

It is not always possible to show the configuration of your EVSE. The illustrations in this document show a typical setup. They are for instruction and description only.

1.6 Units of measurement

SI units of measurement (metric system) are used. If necessary, the document shows other units between parentheses () or in separate columns in tables.









1.7 Typographical conventions



The lists and steps in procedures have numbers (123) or letters (abc) if the sequence is important.

1.8 How to use this document

1. Make sure that you know the structure and contents of this document.
2. Read the safety section and make sure that you know all the instructions.
3. Do the steps in the procedures fully and in the correct sequence.
4. Keep the document in a safe location that you can easily access. This document is a part of the EVSE.

1.9 General symbols and signal words

Signal word	Description	Symbol
Danger	If you do not obey the instruction, this can cause injury or death.	Refer to section 1.10.
Warning	If you do not obey the instruction, this can cause injury.	Refer to section 1.10.
Caution	If you do not obey the instruction, this can cause damage to the EVSE or to property.	
Note	A note gives more data, to make it easier to do the steps, for example.	
-	Information about the condition of the EVSE before you start the procedure.	
-	Requirements for personnel for a procedure.	
-	General safety instructions for a procedure.	
-	Information about spare parts that are necessary for a procedure.	
-	Information about support equipment that is necessary for a procedure.	
-	Information about supplies (consumables) that are necessary for a procedure.	
-	Make sure that the power supply to the EVSE is disconnected.	





Signal word	Description	Symbol
-	Electrotechnical expertise is required, according to the local rules.	
-	Alternating current supply	



Note: It is possible that not all symbols or signal words are present in this document.

1.10

Special symbols for warnings and dangers



Symbol	Risk type
	General risk
	Hazardous voltage that gives risk of electrocution
	Risk of pinching or crushing of body parts
	Rotating parts that can cause a risk of entrapment
	Hot surface that gives risk of burn injuries



Note: It is possible that not all symbols are present in this document.

1.11

Colors of lines in schematic drawings

Lines	Description
	AC input power connections
	DC power connections
	Control lines (general)

1.12 Related documents

Document name	Target group
Product data sheet	All target groups
Installation manual	Qualified installation person
User manual	Owner
Service manual	Qualified service engineer
Declaration of conformity (CE)	All target groups

1.13 Manufacturer and contact data

Manufacturer
 ABB E-Mobility B.V.
 Heertjeslaan 6
 2629 JG Delft
 The Netherlands

Contact data
 ABB E-Mobility B.V. in your country can give you support on the EVSE. You can find the contact data here: <https://new.abb.com/ev-charging>

1.14 Abbreviations

Abbreviation	Definition
AC	Alternating current
BESS	Battery energy storage system
CAN	Controller area network
CPU	Central processing unit
DC	Direct current
EMC	Electromagnetic compatibility
EV	Electric vehicle
EVSE	Electric vehicle supply equipment
EVSS	Electric vehicle site solutions
MID	Measuring Instruments Directive
NFC	Near field communication
NoBo	Notified body
OCCP	Open charge point protocol
PE	Protective earth
PPE	Personal protective equipment
RFID	Radio-frequency identification
UPS	Uninterruptible power supply



Note: It is possible that not all abbreviations are present in this document.

1.15

Terminology

Term	Definition
Network operating center of ABB EV Infrastructure	Facility of the manufacturer to do a remote check on the correct operation of the EVSE
Cabinet	Enclosure of the EVSE, including the components on the inside
Cable slack	Extra length of cable from the top of the foundation so that the cable length is sufficient to connect to the correct terminal in the cabinet
CCS	Combined Charging System, a standard charging method for electric vehicles
CHAdeMO	Abbreviation of <i>CHArge de MOve</i> , a standard charging method for electric vehicles
Grid provider	Company that is responsible for the transport and distribution of electricity
Local rules	All rules that apply to the EVSE during the entire lifecycle of the EVSE. The local rules also include the national laws and regulations
Open charge point protocol	Open standard for communication with charge stations
Owner	Legal owner of the EVSE
Protective devices	Devices for the personal protection of individuals against the risk of injury or electrical shock when they do commissioning, operation and maintenance activities. Examples of protective devices are a door, the electrical parts covers, the latches, etc.
Site operator	Entity that is responsible for the day-to-day control of the EVSE. The site operator does not have to be the owner
User	Owner of an EV, who uses the EVSE to charge the EV



Note: It is possible that not all terms are present in this document.

1.16 Orientation agreements

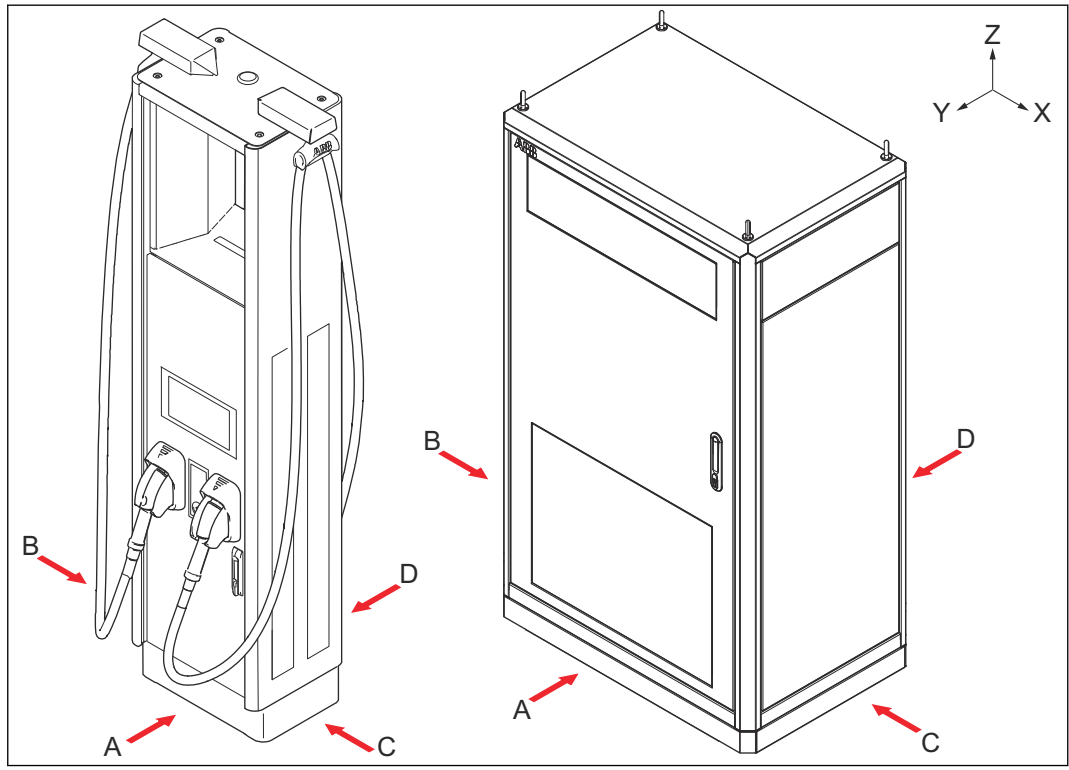

- A Front side: face forward to the EVSE during normal use
- B Left side
- C Right side
- D Rear side

- X X-direction (positive is to the right)
- Y Y-direction (positive is rearward)
- Z Z-direction (positive is upward)

2 Safety

2.1 Liability

The manufacturer is not liable for damages, losses, costs or expenses incurred by any user of the EVSE (e.g. the qualified installation engineer or owner of the EVSE) if such damages, losses, costs or expenses result from a failure to comply with the applicable safety instructions given by the manufacturer, including, but not limited to, the following:

- Power outages or disruptions to the electrical supply to the EVSE.
- Accumulation of dirt or ingress of foreign substances within the EVSE.
- Corrosion of component parts.
- Upgrades enhancements or modifications to the equipment or its use.
- Damage to software or hardware due to any IT security problem, such as but not limited to a virus breakout or malicious hacking of the system.
- Damage or failure of equipment caused by vermin, insect infestations or the like.
- Damage or failure resulting from faults in some other equipment connected to the scope of work.
- Damage or loss caused by hazards such as fire, flood, storm or the like or spillage or leakage of chemicals or harmful substances onto the EVSE.
- Fault tracing caused by problems from a source external to the scope of work.
- Unprofessional or incorrect installation, installation not complying to standards, or installation not following the installation instructions contained in the product specific manual.
- Improper operation (in breach of the technical requirements or specifications or manuals of the product), negligence or repairs carried out by the Owner (or any third party not authorized by ABB).
- Non-compliance with the applicable safety regulations or other legal standards by other parties than ABB.
- Insufficient ventilation of the EVSE.
- Operation of the EVSE outside of its design conditions.
- Relocation of the EVSE from the original installation location or alteration of the overall system design.
- Only make changes to the EVSE if the manufacturer approves in writing of the changes.

2.2 General safety instructions

- Only perform the procedures as indicated in this document.
- Only perform service by a qualified installation engineer or use the EVSE when you are fully qualified to do so.
- Comply with the applicable laws and local rules in this manual.





If and to the extent permitted by law, in case of inconsistency between any requirements or procedure contained in this document and any such applicable laws and local rules, comply with the stricter applicable laws and local rules, requirements and procedures specified in this document.

2.3 Required qualifications for the installation person





- The qualified installation person knows the EVSE and its safe installation.
- The installation person is qualified according to the applicable local rules to do the work.
- The qualified installation person obeys all local rules and the instructions in the installation manual.
- It is the responsibility of the owner of the EVSE to make sure that all qualified installation persons obey the local rules, the installation instructions, and the specifications of the EVSE.

2.4 Personal protective equipment

Symbol	Description
	Protective clothing
	Safety gloves
	Safety shoes
	Safety glasses

2.5 Safety instructions during transport

Preliminary requirements









	<ul style="list-style-type: none"> • Qualified installation engineer 		<ul style="list-style-type: none"> • 
---	---	--	---

- Make sure that the hoisting equipment or forklift truck can lift the EVSE safely. Take into account the mass and the center of gravity of the EVSE. Refer to section 12.12.

- Obey the applicable safety instructions for the hoisting equipment or for the forklift truck. For example, the instructions specified on the related shipment label that is applied to the EVSE packaging.
- Put on the correct personal protective equipment. Refer to section 2.4.

2.6 Safety instructions during installation

Preliminary requirements

	<ul style="list-style-type: none"> •  Qualified installation engineer 		<ul style="list-style-type: none"> •     
---	---	---	--

- Make sure that there is no voltage on the AC input cables during the complete installation procedure.
- Keep unqualified personnel at a safe distance during installation.
- Only use electrical wires of sufficient gauge and insulation to handle the rated current and voltage demand.
- Make sure that the load capacity of the grid is in accordance with the EVSE.
- Earth the EVSE correctly. Refer to section 2.7.
- Make sure that the wiring inside the EVSE is protected from damage and cannot get trapped when you open or close the cabinet.
- Make sure that water cannot enter the cabinet.
- Protect the EVSE with safety devices and measures that the local rules specify.
- If it is necessary to remove safety devices for maintenance or repairs, immediately install the safety devices after the work is completed.
- Put on the correct personal protective equipment. Refer to section 2.4.









2.7 Safety instructions for earthing

Preliminary requirements

	<ul style="list-style-type: none"> •    
---	--

- Make sure that the EVSE is connected to a grounded, metal, permanent wiring system. If that is not possible, then an equipment-grounding conductor must be run with the circuit conductors. The equipment-grounding conductor must be connected to the equipment grounding terminal or lead on the product.
- Make sure that the connections to the EVSE comply with all applicable local rules.

2.8 Signs on the EVSE

Symbol	Description
	General risk
	Hazardous voltage that gives risk of electrocution
	Risk of pinching or crushing of body parts
	Rotating parts that can cause a risk of entrapment
	Hot surface that gives risk of burn injuries
	Appliance class 1
	Sign that means that you must read the manual before you use or install the EVSE
	Waste from electrical and electronic equipment



Note: It is possible that not all symbols are present on the EVSE.



2.9 Identifier labels on the EVSE (EN 17186 norm)

The EVSE has identifier labels on the connectors. The identifier labels help EV owners to select the correct EV charge connector for their EV, or the correct charger socket for the EV charge cable of the EV. These labels for 'Identification of vehicles and infrastructures compatibility' are defined by the European Directive 2014/94/EU Alternative Fuels Infrastructure (AFI), based on the *EN 17186* norm. The identifier labels must be in these locations:

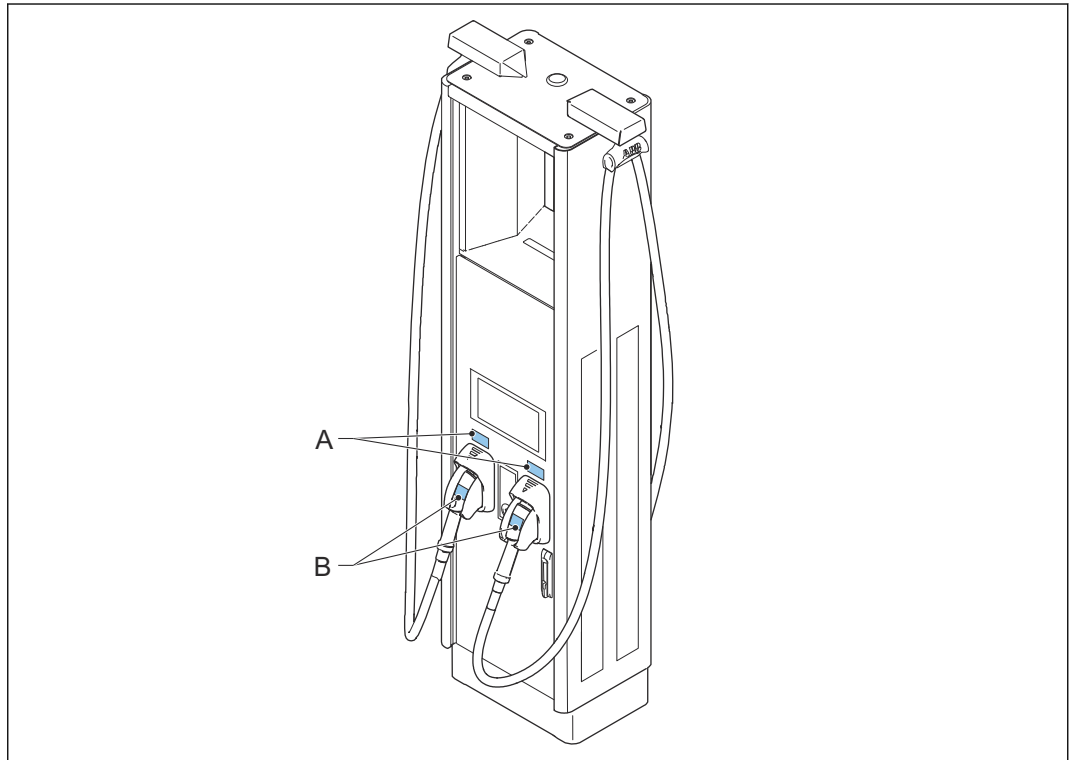
- On each connector
- Close to each connector holder
- Close to the EV inlet (charge port)



A Location of the large size identifier B Location of the minimum size identifier

DC identifier	Outlet	Standard	EV cable type	Voltage
	CCS	EN 62196.3 FF	CCS combo 2 (DC part)	500-1000 V
	CHAdeMO	EN 62196.3 AA	CHAdeMO(DC part)	0-500 V

2.10

Discard the EVSE or parts of the EVSE

Incorrect waste handling can have a negative effect on the environment and human health due to potential hazardous substances. With the correct disposal of this product, you contribute to reuse and recycling of materials and protection of the environment.

- Obey the applicable laws and local rules when you discard parts, packaging material or the EVSE.
- Discard electrical and electronic equipment separately in compliance with the WEEE - 2012/19/EU Directive on waste of electrical and electronic equipment.
- As the symbol of the crossed out wheeled-bin on your EVSE indicates, do not mix or dispose the EVSE with your household waste, at the end of use. Instead, hand the EVSE over to your local community waste collection point for recycling.
- For more information, contact the Government Waste-Disposal department in your country.

2.11 Cyber security



Note: This topic is valid for a wired Ethernet connection.

This product is designed to be connected to and to communicate information and data via a network interface. It is the Owner's sole responsibility to provide and continuously ensure a secure connection between the product and Owner's network or any other network (as the case may be).

The Owner shall establish and maintain any appropriate measures (such as but not limited to the installation of firewalls, application of authentication measures, encryption of data, installation of anti-virus programs, etc) to protect the product, the network, its system and the interface against any kind of security breaches, unauthorized access, interference, intrusion, leakage and/or theft of data or information.

The manufacturer (ABB E-Mobility B.V.) and its affiliates are not liable for damages and/or losses related to such security breaches, any unauthorized access, interference, intrusion, leakage and/or theft of data or information.

3 Description

3.1 Intended use

The EVSE is intended for DC high power charging of EVs. The EVSE is intended for indoor or outdoor use.

- The properties of the electrical grid, the ambient conditions and the EV must comply with the technical data of the EVSE. Refer to chapter 12.
- Only use the EVSE with accessories that are approved by the manufacturer (ABB E-Mobility B.V.) and that obey the local rules.
- Do not use power cabinets from this EVSE with power cabinets from different EVSEs.



Danger:

General risk

- If you use the EVSE in any other way than described in the related documents, you can cause death, injury and damage.
- Use the EVSE only as intended.

3.2 Type plate

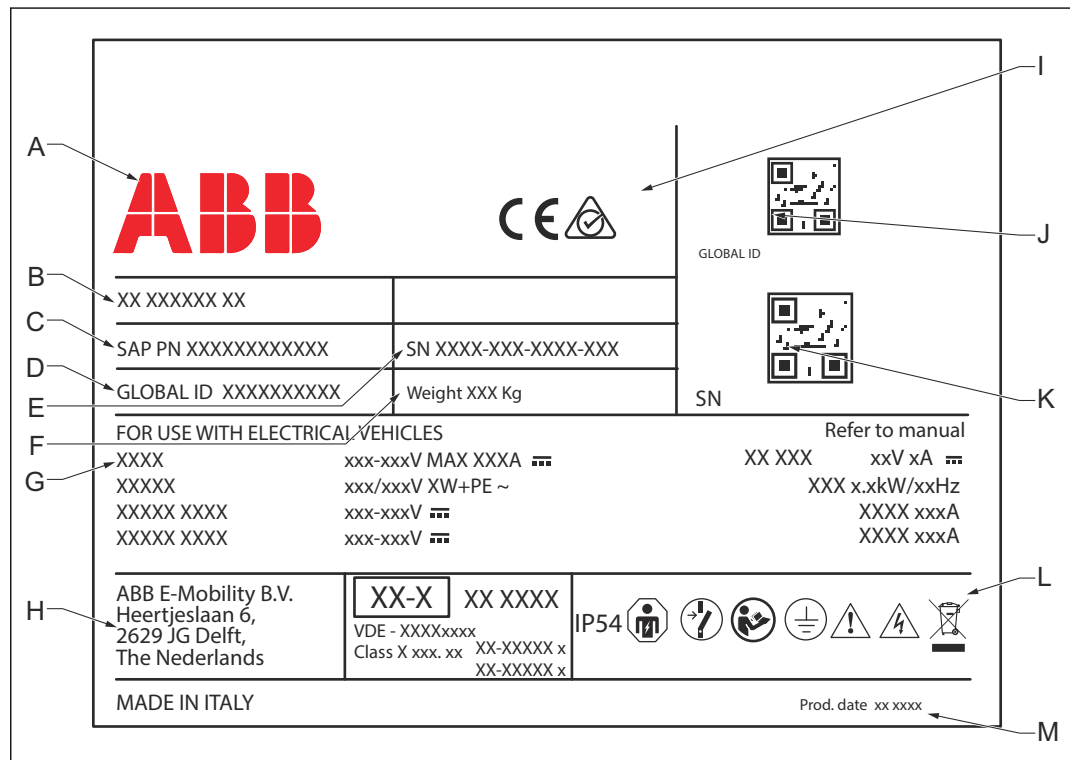

- | | | | |
|---|--|---|---|
| A | Manufacturer | H | Address of the manufacturer |
| B | Full EVSE type | I | CE mark |
| C | Part number of the EVSE | J | QR code with the internal product code (for the manufacturer) |
| D | Serial number | K | QR code with the serial number of the EVSE |
| E | Internal product code (for the manufacturer) | L | Additional EVSE rating data |
| F | EVSE mass | M | Production date |
| G | EVSE rating | | |



Note: The data in the illustration are only examples. Find the type plate on your EVSE to see the applicable data.

- For the location of the type plate, refer to section 3.5.
- For the EVSE type information, refer to section 12.1.

3.3 General description of the EVSE

The EVSE is an arrangement of these parts:

- Substation
- Power cabinet
- Charge post

An arrangement can have one or more power cabinets and one or more charge posts. For the specifications of the configuration in this manual, refer to section 3.4.



3.4 Working principle

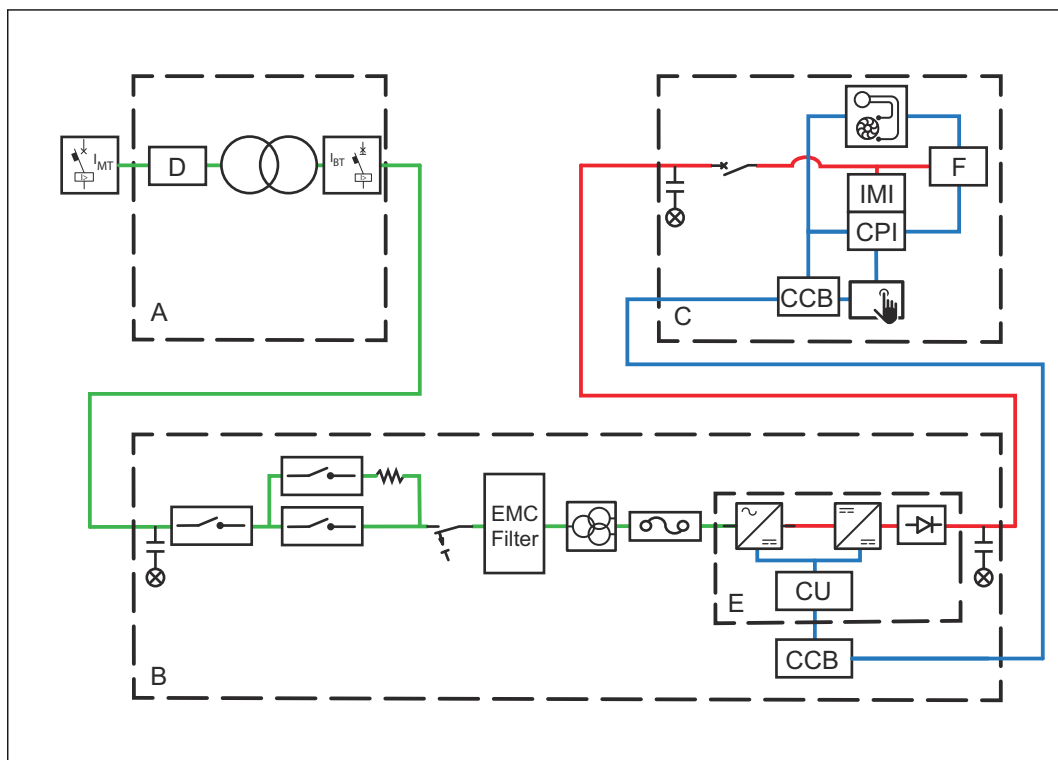

Note: For a detailed overview of the electrical connections, refer to section 12.23.



- | | | | |
|---|---------------|---|------------------------|
| A | Substation | D | Electrical grid supply |
| B | Power cabinet | E | Power module (x3) |
| C | Charge post | F | EV charge cable |

Lines	Description
	AC input power connections
	DC power connections
	Control lines (general)

3.5 Overview and functions

3.5.1 Power cabinet, outside

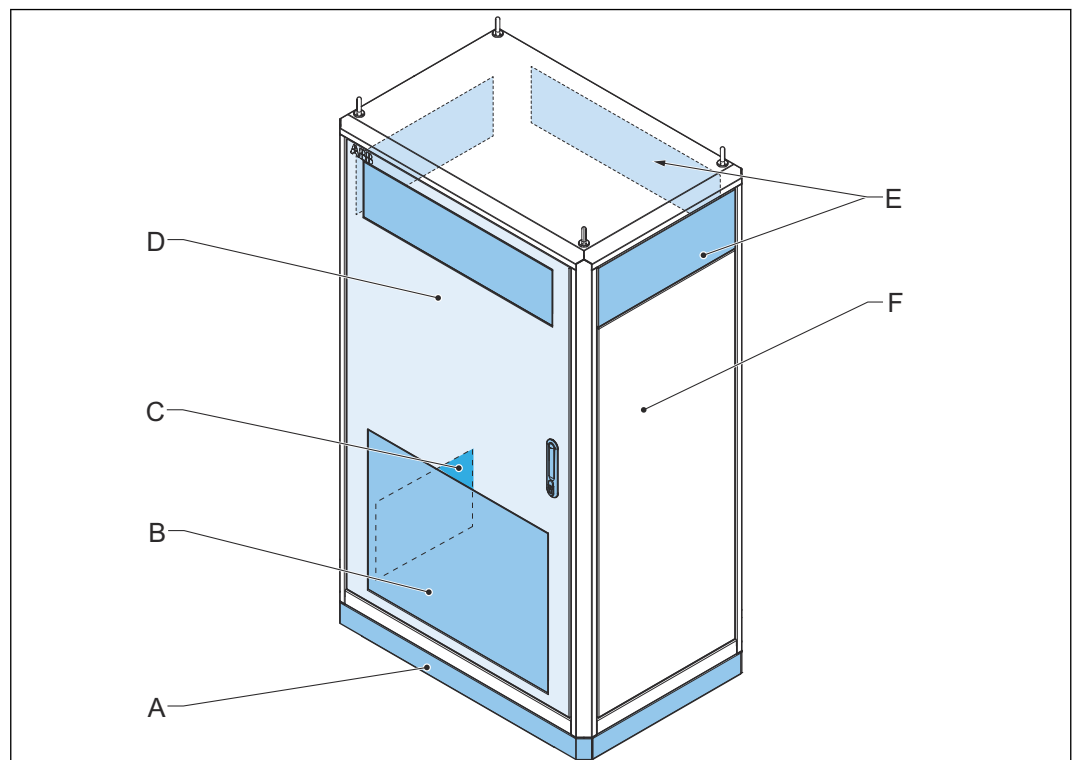

A Plinth cover
 B Air outlet
 C Type plate

D Door
 E Air inlet (4x)
 F Enclosure

3.5.2 Power cabinet, inside

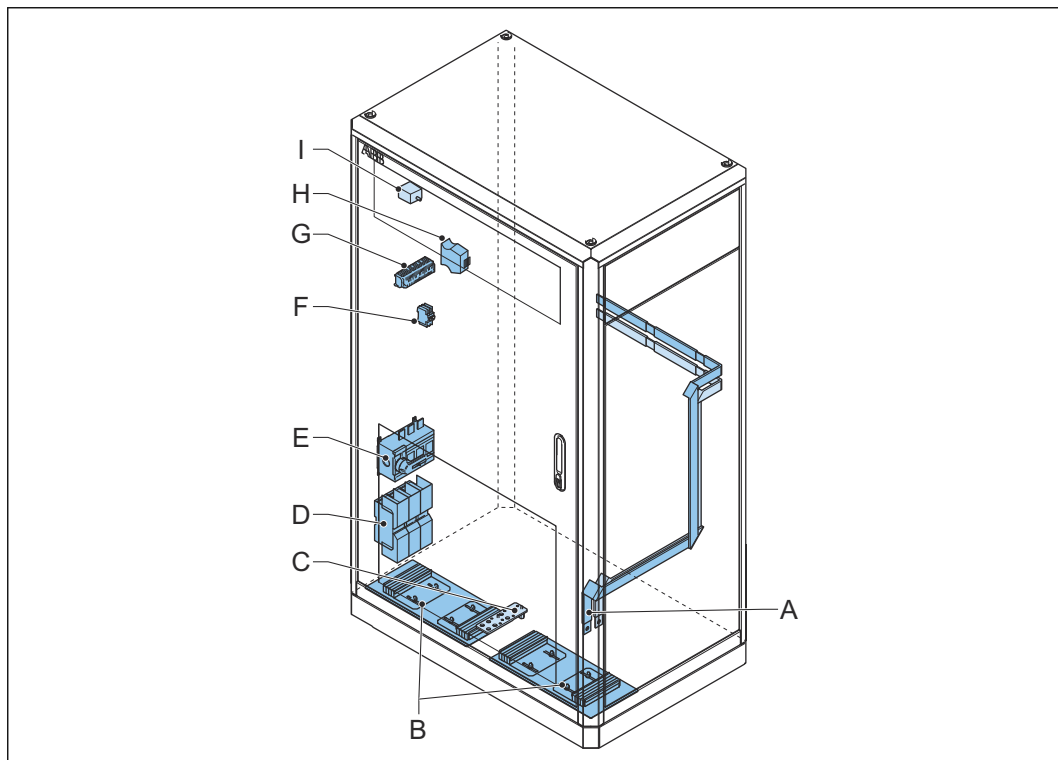

A	DC output busbars	F	X-10 terminal block
B	Cable inlets	G	X-8 terminal block
C	PE busbar	H	CAN2FIBER device
D	AC power connector	I	Tilt sensor (option)
E	Main switch		

Part	Function
DC output busbar	To connect the DC output power cables
Cable inlet	A plate with openings for cables
PE busbar	To connect PE cables
AC power connector	To connect to the AC input power cable
Main switch	To connect or disconnect the AC power
X-10 terminal block	To connect to the AC auxiliary power cable
X-8 terminal block	To connect the interlock, DC guard, and CAN cables
CAN2FIBER device	To connect the optical CAN cable
Tilt sensor (option)	To detect the tilt of the power cabinet

3.5.3 DC output busbar in a static DC system

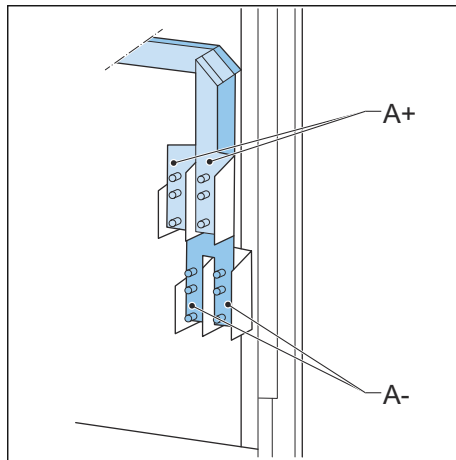

A+ Positive DC output busbar

A- Negative DC output busbar

3.5.4 Charge post CP500 Generation 3, outside

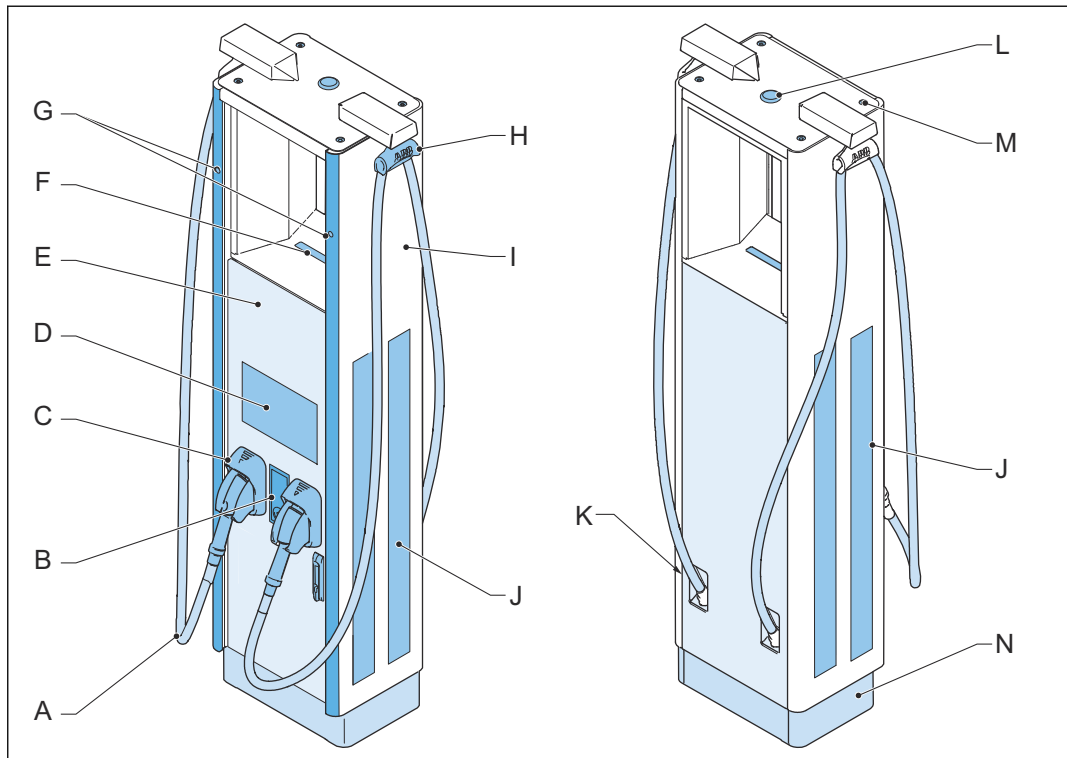

- A EV charge cable
- B RFID reader and the payment terminal (option)
- C Connector holder
- D Touchscreen
- E Door
- F Top light
- G Side LED strips

- H Cable retraction system
- I Enclosure
- J Air inlet and outlet
- K Type plate
- L Antenna
- M Hoisting points
- N Plinth cover

3.5.5

Charge post CP500 Generation 3, inside

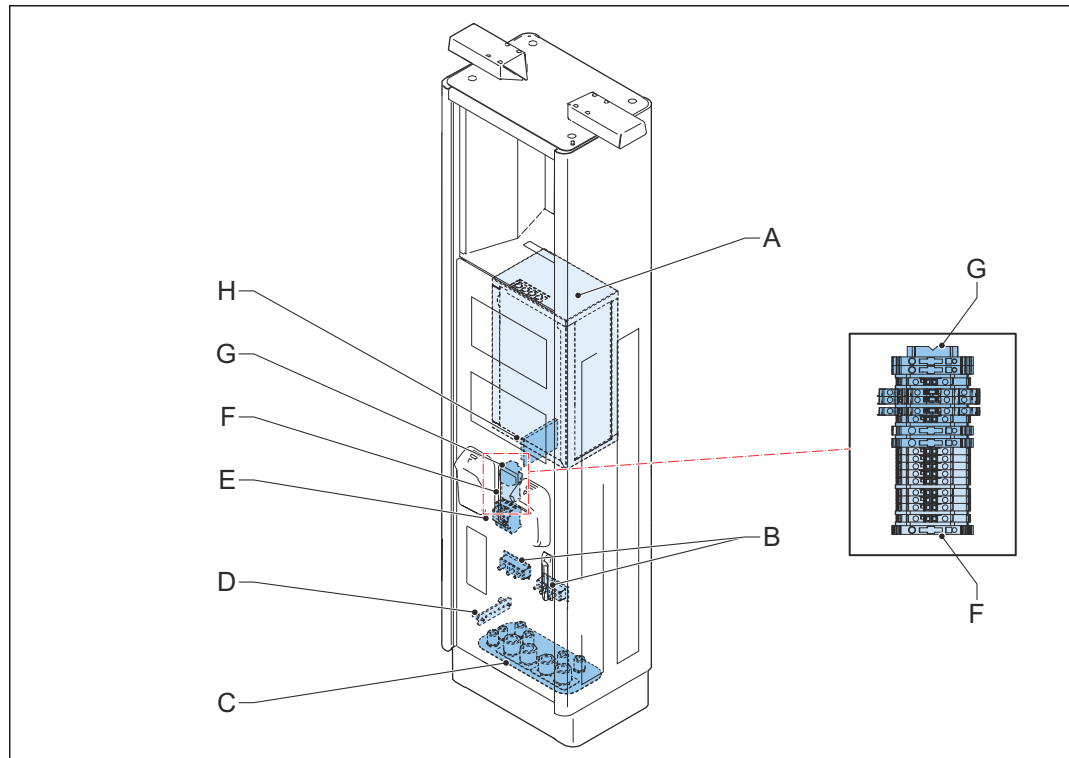

A	Cooling unit	E	Q1 RCD
B	DC power busbars	F	X-10 terminal block
C	Cable gland plates	G	X-20 terminal block
D	PE busbar	H	CAN2FIBER device

Part	Function
Cooling unit	To decrease the temperature of the charge cables
DC power busbars	To connect the DC power cables
Cable gland plates	Glands for the cables to the charge post
PE busbar	To connect the PE wire
Q1 RCD	Residual current circuit breaker to connect or disconnect the AC auxiliary power to the charge post
X-10 terminal block	To connect the AC auxiliary power cable
X-20 terminal block	To connect the interlock and DC guard cable
CAN2FIBER device	To connect the optical CAN cable

3.5.6 Overview of the cable glands of the charge post

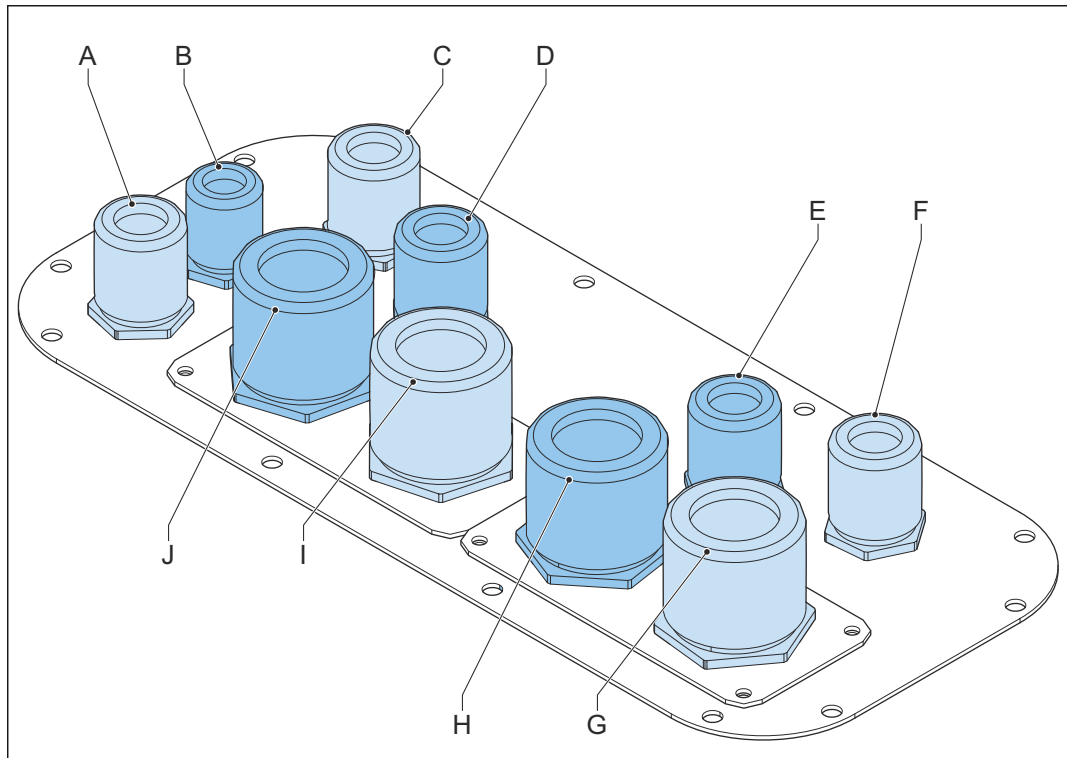

A	PE wire	F	Ethernet cable
B	AC auxiliary power cable	G	DC+ in cable
C	Optical CAN cable	H	DC+ in cable
D	Tilt sensor control cable (optional)	I	DC- in cable
E	Interlock and DC guard cable	J	DC- in cable

3.6 External residual-current device

The manufacturer does not supply an external residual-current device. If an external residual-current device is required because of local rules, this section helps you to select the correct device.

Situation: the local rules require an immunity for short current peaks over PE during the EV charging process

At the start of the EV charge cycle, a relay switches and engages the AC input power to the power modules. Incidental current peaks can occur.

A combination of these factors is the source of these current peaks:

- Asynchronous engagement of the phases in the relay
- The electrical capacity of the AC input power part of the EVSE

The amplitude of the current peaks can change. These factors are the source of the differences:

- The location of the EVSE
- The power grid
- The earth impedance

For the specifications of the residual-current device and the incidental current peaks, refer to sections 12.7 and 12.11.

3.7 Options

3.7.1 Tilt sensors

The tilt sensor system disables the power from the incoming low voltage source when a tilt sensor detects a tilt of a cabinet of the EVSE in any direction. The tilt sensor is generally closed and opens when there is an unacceptable tilt of the cabinet. For the threshold tilt, refer to section 12.13.

The tilt sensors require a 24 V power supply, daisy chain-connected from the power cabinets to the charge post. This power supply is not included in the scope of ABB E-Mobility B.V.. ABB E-Mobility B.V. recommends to use an uninterruptible power supply.

It is possible to install tilt sensors afterwards. Ask ABB E-Mobility B.V.. Refer to section 1.13.

Example: An incident such as a heavy duty vehicle that crashes into the charge post can open the tilt sensor.

Example of a connection scheme:

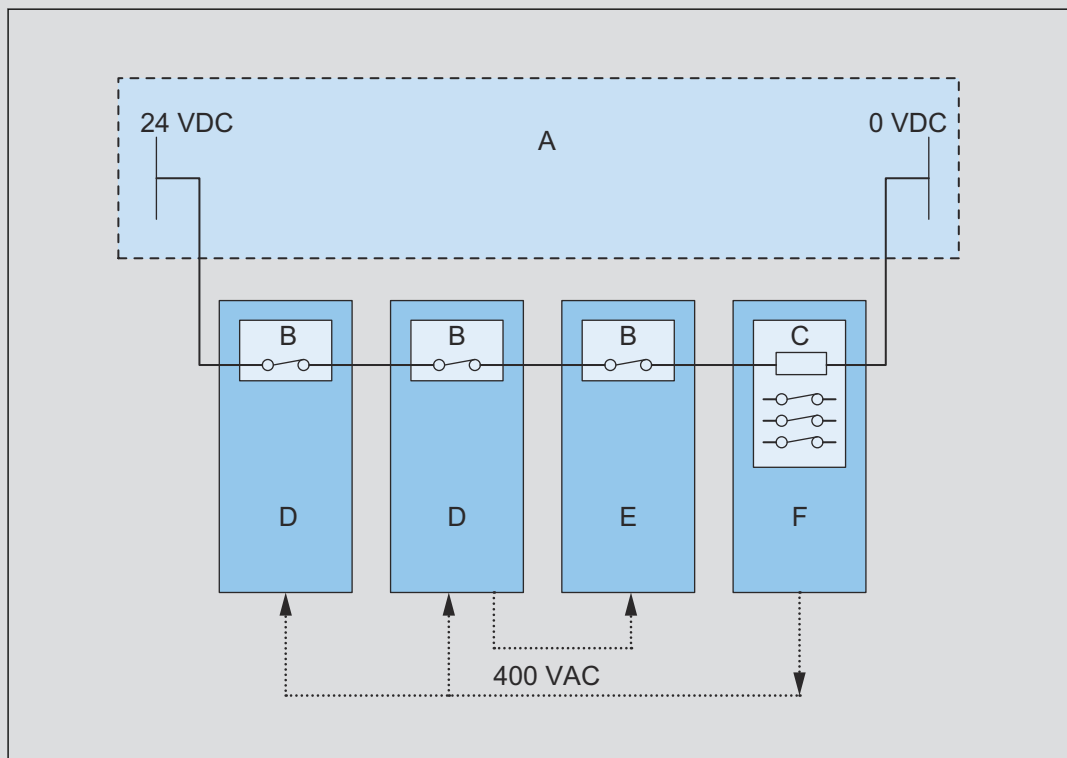



- A** 24 V power supply
- B** Tilt sensor
- C** Undervoltage release
- D** Power cabinet
- E** Charge post
- F** Substation

4 Pre-installation

4.1 Pre-installation procedure (site planning)

Preliminary requirements

<input checked="" type="checkbox"/>  <input checked="" type="checkbox"/>  <input type="checkbox"/> 	<ul style="list-style-type: none"> All required permits to comply with the local rules, are granted.
--	---

Procedure

- Do a check on the configuration of the EVSE. Refer to the order.
- Refer to the specifications to prepare and order these items:
 - Foundations. Refer to section 12.19.
 - Cable specifications. Refer to section 12.21.
- Make sure that the cable slack for each cable is sufficient to guide the cables in the cabinets. Refer to section 12.17.
- Prepare the site. Refer to section 4.2.
- Make sure that the floor space for the EVSE and the airflow around the EVSE is correct. Refer to section 4.3.
- Prepare the underground installation:
 - Prepare the cable conduits. For the overview of the cable conduits, refer to section 12.20.
 - Prepare the foundations. Refer to section 4.4.
- If the local rules require the installation of extra items, plan the installation of these items.

Examples:

- External residual-current device. Refer to section 3.6.
- Options. Refer to section 3.7.

4.2 Prepare the site

- Make sure that the design of the site complies with these specifications:
 - The length of the charge cables is sufficient for connection to the charge inlet of the EV. For the length and cable reach of the charge cables, refer to section 12.18.2.
 - The maximum distance between the power cabinet and the charge post. Refer to section 12.18.4.
- Create a slope to drain the water away from the EVSE.
- Create a parking space that allows the EV to have easy access to the EV charge cable.
- Apply road signs or markings to indicate that the parking space is intended for EV charge sessions.
- Install barriers or posts around the power cabinet and between the charge post and the parking space.
- Increase the height of the pavement and make sure that it is clearly visible, to prevent damage of the EV.

7. Make sure that the site complies with the relevant usability standards, such as ADA and DIN 18040:
 - a. Limit the curb heights.
 - b. Take into account the limited reach of a wheelchair user.
For usability standards specifications, refer to section 12.17.3.
8. Make the site as safe as possible.
 - a. Make sure that the EVSE can be clearly seen and monitored.
 - b. Apply 24/7 security control.
 - c. Install sufficient lighting.

4.3 Make sure that the floor space for the EVSE and the airflow around the EVSE is correct

1. Make sure that the floor spaces meet the requirements. Refer to section 12.18.
2. Make sure that the air flow inlet and outlet cannot get blocked. Think of snow or objects.

4.4 Prepare the foundation

4.4.1 Prepare the foundation - general procedure

1. Select the correct foundations, according to the ground conditions.
2. Prepare the foundation for the power cabinet.

Type	Procedure
Prefab concrete foundation	Refer to section 4.4.2.
Custom foundation	Refer to section 4.4.3.

3. Prepare the foundation for the charge post.

Type	Procedure
Prefab concrete foundation	Refer to section 4.4.4.
Custom foundation	Refer to section 4.4.5.

4.4.2 Prepare a prefab concrete foundation for the power cabinet

Preliminary requirements

	<ul style="list-style-type: none"> • Prefab concrete foundation. Refer to section 12.19.1.
---	---

Procedure

1. Contact the manufacturer to order the foundation for your EVSE. Refer to section 1.13.
2. Dig the hole for the foundation.



Caution: Make sure that the top surface of the foundation is above the ground level, to prevent intrusion of water.

3. Guide the cable conduits into the holes of the foundations:
 - Holes (A): CAN, interlock and DC guard or AC auxiliary power and PE cables
 - Holes (B): DC or AC power cables

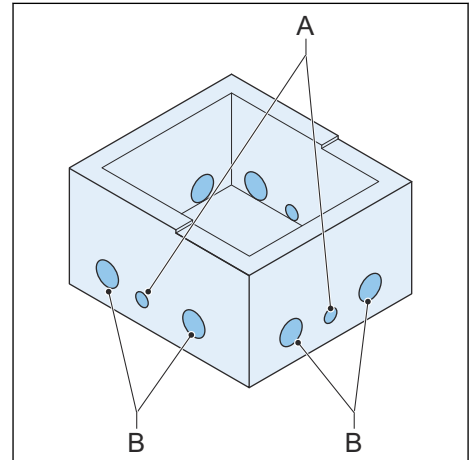

4. Install the foundation in the hole.
5. Pull the cables through the cable conduits in the foundation. Apply the full cable slack.

For the specification of the cable slack, refer to section 12.17.1.

6. Fill the foundation with gravel or another substance to prevent rodents to enter the cabinet.

4.4.3 Prepare a custom foundation for the power cabinet

Preliminary requirements



- Custom foundation. Refer to section 12.19.2.

Procedure

1. Make the custom foundation.



Caution: Make sure that the top surface of the foundation is above the ground level, to prevent intrusion of water.

2. Guide the cables into the holes (C1) to (C7) of the foundations. For the relation between the cables and the holes, refer to section 12.19.2.
3. Install the foundation in the hole.
4. Put the cables through the openings in the foundation. Apply the full cable slack.

For the cable slack, refer to section 12.17.

5. Fill the foundation with gravel or another substance to prevent rodents to enter the cabinet.

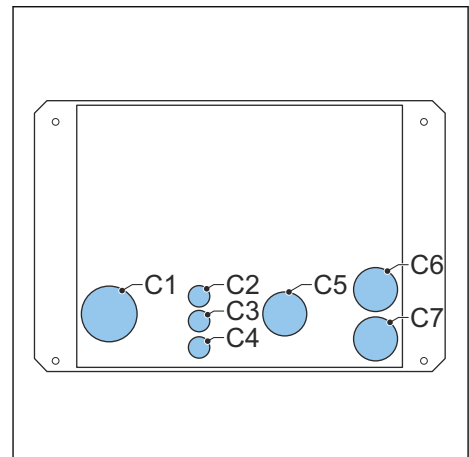

4.4.4 Prepare a prefab concrete foundation for the charge post

Preliminary requirements

	<ul style="list-style-type: none"> • Prefab concrete foundation. Refer to section 12.19.3.
---	---

Procedure

1. Contact the manufacturer to order the foundation for your EVSE. Refer to section 1.13.
2. Dig the hole for the foundation.



Caution: Make sure that the top surface of the foundation is above the ground level, to prevent intrusion of water.

3. Guide the cable conduits into the holes of the foundations.
4. Install the foundation in the hole.
5. Pull the cables through the cable conduits in the foundation. Apply the full cable slack.

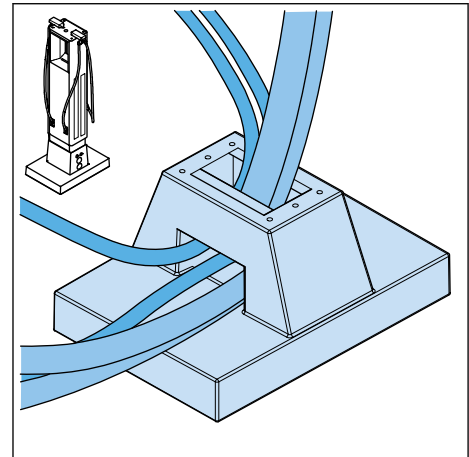

For the specification of the cable slack, refer to section 12.17.2.

6. Fill the foundation with gravel or another substance to prevent rodents to enter the cabinet.

4.4.5 Prepare a custom foundation for the charge post

Preliminary requirements

	<ul style="list-style-type: none"> • Custom foundation. Refer to section 12.19.
---	--

Procedure

1. Make the custom foundation.



Caution: Make sure that the top surface of the foundation is above the ground level, to prevent intrusion of water.

2. Guide the cables into the holes (C1) to (C4) of the foundations. For the relation between the cables and the holes, refer to section 12.19.4.
3. Install the foundation in the hole.
4. Put the cables through the openings in the foundation. Apply the full cable slack.

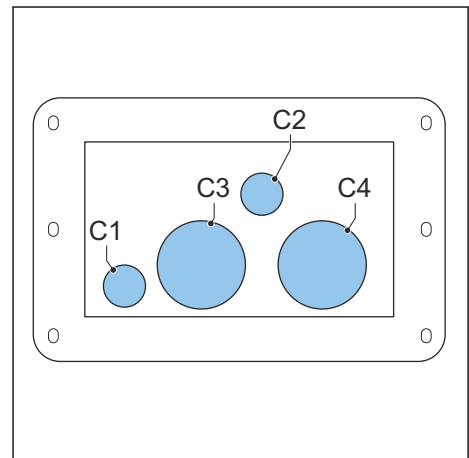

For the cable slack, refer to section 12.17.

5. Fill the foundation with gravel or another substance to prevent rodents to enter the cabinet.

5 Inspection and transport

5.1 Transport the EVSE to the site

A transport company delivers the EVSE close to the site. The movement of the EVSE to its final location is the responsibility of the transport company. If you need to store the EVSE before installation, obey the ambient conditions for storage. Refer to section 12.14.



Caution: YOU ARE PROHIBITED FROM TRANSPORTING OR HANDLING THE EV CHARGER UNLESS YOU ARE AUTHORISED TO HANDLE THE CHARGER AND YOU COMPLY WITH THE FOLLOWING SAFETY MEASURES!



Warning: Please follow these steps to comply with the applicable Safety measures applicable to the working area including Instructions for safe handling of the EV Charger

- Check the weight on the transport document before moving the load. Make sure that the offloading equipment used can handle this specific weight.
- Check that the forklift truck or hoisting equipment for loading/unloading is suitable, able to move the EV Charger based on weight, and that the forks of the forklift truck is fully able to move into the pallet to provide full support. Forklift operators must comply to all local regulations.
- Handling personnel must wear all appropriate and applicable personal protective equipment (PPE) and follow all the applicable Health and Safety measures applicable to the working area.
- Check the position of the center of gravity before lifting the EV Charger – the higher the position of center of gravity, the more care is required to handle the EV Charger to avoid overturning.
- Check that the pallet is not damaged. If there is damage, contact the responsible Health and Safety manager for the site to get instructed on how to unload the EV Charger and move it in a safe way.
- Check that the working place conditions are safe before handling the load (such as obstacle-free unloading area, proper flooring, safe path and other conditions).
- Ensure that the area is not accessible to unauthorized personnel and the personnel involved in handling the EV Charger are fully aware of the safety measures to apply when handling the EV Charger and keep sufficient distance away from the moving EV Charger.

ABB is not liable for any damages resulting from the improper handling and transportation of the Electrical Vehicle Charger, in particular damage resulting from non-compliance with these instructions and other applicable regulations and standards (e.g. transport, occupational health and other safety standards).

5.2 Inspect the EVSE on delivery

1. Do a check on the transport sensors. Refer to section 5.3.
2. Unpack the EVSE. Refer to section 5.4.
3. Do a check if the EVSE is in accordance with the order.
4. Do a check on the EVSE for damage.
5. If the EVSE shows damage or is not in accordance with the order, tell the transport company immediately.

5.3 Do a check of the transport sensors

Preliminary requirements

	<ul style="list-style-type: none"> Installation engineer
---	---

Procedure

1. Do a check on the sensors (A) that record the shocks during transport.
2. Do a check on the sensors (B) that record the maximum tilt during transport.
3. If the sensors (A) show a red indication or the sensors (B) show a tilt that is too high, do these steps:
For the transport specifications, refer to section 12.5.

- a. Accept the delivery of the EVSE.
- b. Make a note on the delivery receipt.
- c. If damage occurred, leave the item in its original packaging and request an immediate inspection from the carrier within the applicable time period.

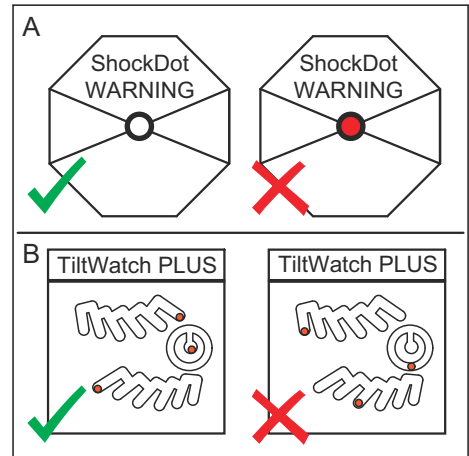

5.4 Unpack the EVSE

1. Remove the packaging material.
2. Discard the packaging material. Refer to section 2.10.
3. Remove the cabinet from the pallet. Refer to section 5.6.

5.5 Transport the EVSE on the site

5.5.1 General transport procedure

Preliminary requirements

	<ul style="list-style-type: none"> The cabinets are unpacked. Refer to section 5.4.
---	--



Note: The charge post is delivered horizontally or vertically.



Caution: Do not tilt the power cabinet to the horizontal position. In the horizontal position, the power cabinet breaks.

Procedure

1. Move the power cabinet to the installation location:
 - Move the cabinet with a forklift truck. Refer to section 5.5.3.
 - Hoist the cabinet. Refer to section 5.5.4.
2. Move the charge post to the installation location:

Situation	Procedure
Tilt the charge post to the vertical position.	Refer to section 5.5.2.
Move the charge post with a forklift truck.	Refer to section 5.5.3.
Hoist the charge post.	Refer to section 5.5.4.

5.5.2

Tilt the charge post to the vertical position

Preliminary requirements

	<ul style="list-style-type: none"> • The charge post is in the horizontal position. • The charge post is unpacked. Refer to section 5.4. 		<ul style="list-style-type: none"> • Hoisting equipment, including cables, swivel eye bolts or bolts with lifting loops. Refer to section 12.3.
--	--	--	--



Warning:

Risk of pinching or crushing, the charge post is heavy

- Make sure that the hoisting equipment can lift the charge post safely. Obey the safety instructions that apply to the hoisting equipment. Take into account the dimensions, the mass and the center of gravity of the charge post. Refer to chapter 12.



Caution:

- Do not drop the charge post. There is a risk of damage.

Procedure

1. Install the swivel eye bolts or bolts with lifting loops (A).
2. Connect the hoisting equipment (B).
3. Carefully tilt the charge post (C) to the vertical position.
4. Remove the swivel eye bolts or bolts with lifting loops (A).

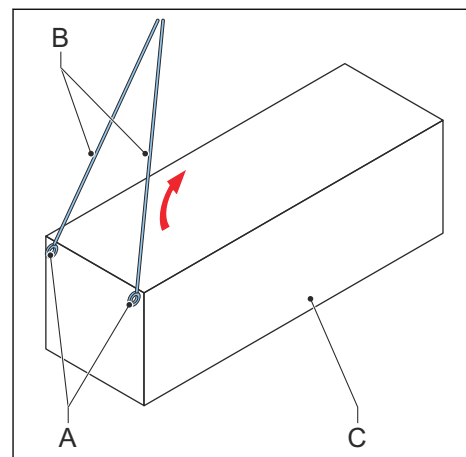

5.5.3 Move the cabinet with a forklift truck

Preliminary requirements

	<ul style="list-style-type: none"> The cabinet is unpacked. Refer to section 5.4. 		<ul style="list-style-type: none"> Forklift truck. Refer to section 12.3.
--	--	--	--



Warning:

Risk of pinching or crushing, the cabinet is heavy

- Make sure that the forklift truck can lift the cabinet safely. Obey the safety instructions that apply to the forklift truck. Take into account the mass, the dimensions and the center of gravity of the EVSE. Refer to sections 12.12 and 12.17.



Caution: Do not drop the cabinet.

Procedure

- Move the forks (A) of the forklift truck in the gaps at the side of the cabinet.
- Move the cabinet to the correct location.

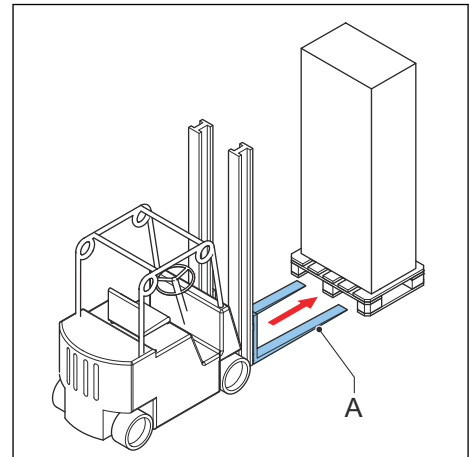

5.5.4 Hoist the cabinet

Preliminary requirements

	<ul style="list-style-type: none"> The cabinet is unpacked. Refer to section 5.4. 		<ul style="list-style-type: none"> Hoisting equipment, including cables (not chains), swivel eye bolts or bolts with lifting loops. Refer to section 12.3.
--	--	--	---



Warning:

Risk of pinching or crushing, the cabinet is heavy

- Make sure that the hoisting equipment can lift the cabinet safely. Obey the safety instructions that apply to the hoisting equipment. Take into account the dimensions, the mass and the center of gravity of the EVSE. Refer to sections 12.12 and 12.17.



Caution:

- Do not drop the cabinet.
- Make sure that there are no dynamic forces on the hoisting points.
- Make sure that the weight is equally distributed between the hoisting points.

Procedure

1. Install the swivel eye bolts or bolts with lifting loops (A).
2. Connect the cables (B) of the hoisting equipment to the swivel eye bolts or bolts with lifting loops.
3. Move the cabinet to the correct location.
4. Remove the swivel eye bolts or bolts with lifting loops (A).
5. Install the plastic cover on the threaded location.

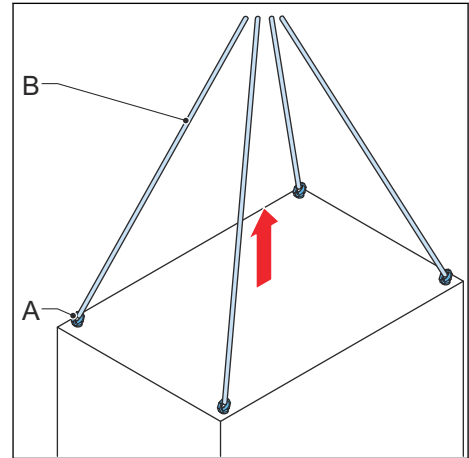

5.6 Remove the cabinet from the pallet

Preliminary requirements

	<ul style="list-style-type: none">• Open spanner
--	--

Procedure

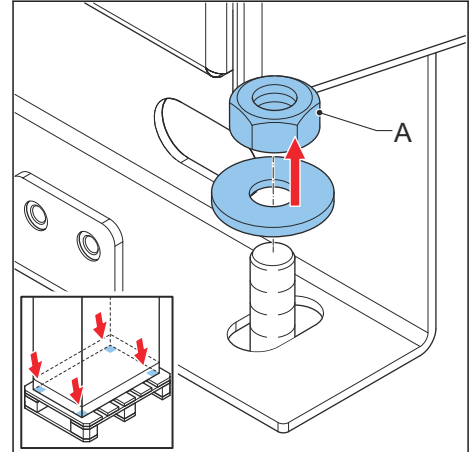

1. Remove the fasteners (A).
2. Discard the fasteners and the pallet. Refer to section 2.10.



6 Installation

6.1 General installation procedure

Preliminary requirements

	<ul style="list-style-type: none"> The AC input cable is available. The foundations for the cabinet is prepared. All cables are in the cable conduits and the full cable slack is applied. The substation is prepared. The site is prepared. 		<ul style="list-style-type: none"> There is no voltage on the AC input cable during the complete installation procedure.
	<ul style="list-style-type: none"> Tools for installation. Refer to section 12.3. 		

Procedure

1. Do the mechanical installation of the power cabinet. Refer to section 6.2.
2. Do the mechanical installation of the charge post. Refer to section 6.3.
3. Do the electrical installation of the power cabinet. Refer to section 7.
4. Do the electrical installation of the charge post. Refer to section .
5. Prepare for commissioning. Refer to section 9

6.2 Mechanical installation of the power cabinet

6.2.1 Install the power cabinet - general procedure

Preliminary requirements

	<ul style="list-style-type: none"> The cabinet is above the foundation.
---	--

Procedure

1. Remove the plinth covers of the power cabinet. Refer to section 10.7.
2. Install the cabinet on the foundation. Refer to section 6.2.2.
3. Open the cable inlets. Refer to section 6.2.3.
4. Guide the cables to the power cabinet. Refer to section 6.2.4.
5. Close the cable inlets. Refer to section 6.2.5.
6. Install these parts:
 - a. Cover plate of the foundation. Refer to section 6.2.6.
 - b. Plinth covers of the power cabinet.
7. Replace the eye bolts on the power cabinet with the caps. Refer to section 12.2.

6.2.2 Install the cabinet on the foundation

Preliminary requirements

	<ul style="list-style-type: none"> • Hoisting equipment or forklift truck • Torque wrench 		<ul style="list-style-type: none"> • Four fasteners M16 and washers
---	---	--	--

Procedure

1. Carefully lower the cabinet on the foundation with a hoisting equipment or a forklift truck. Refer to section 5.5.1.



Caution: Make sure that there is no kink in the cables.

2. Make sure that the holes in the cabinet (A) and the foundation (B) are aligned.
3. Install the fasteners (C) and the washers.
4. Tighten the fasteners to the correct torque. For the specification, refer to section 12.16.

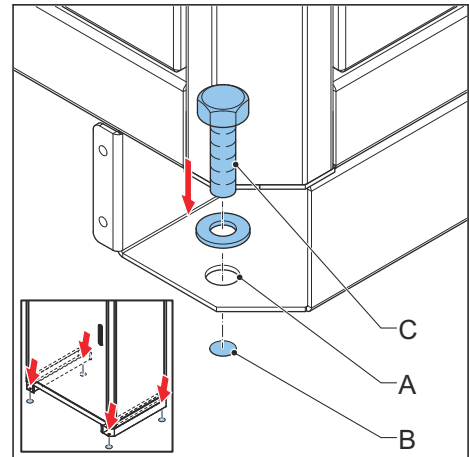

6.2.3 Open the cable inlets

Preliminary requirements

	<ul style="list-style-type: none"> • Open spanner
---	--

Procedure

1. Open the door. Refer to section 10.1.
2. Loosen the fasteners (A).
3. Move the sliding plates (B) to open the cable inlets.

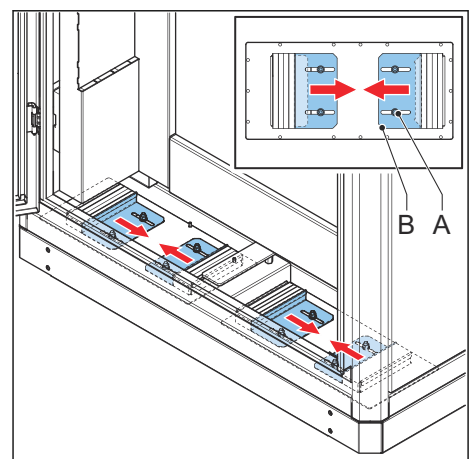

6.2.4 Guide the cables to the cabinet

Preliminary requirements

	<ul style="list-style-type: none"> • The cable inlets are open.
---	--

Procedure

1. Guide the AC input cable, the AC auxiliary power cable, the interlock and DC guard and the CAN cables (A) through the opening (B).
2. Guide the DC output cables (C) through the opening (D).

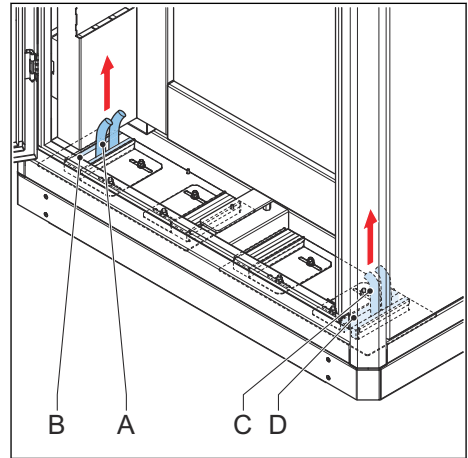

6.2.5

Close the cable inlets

1. Move the sliding plates (B) on the guidance plate to close the cable inlets and hold the cables (C) in place.
2. Tighten the fasteners (A).

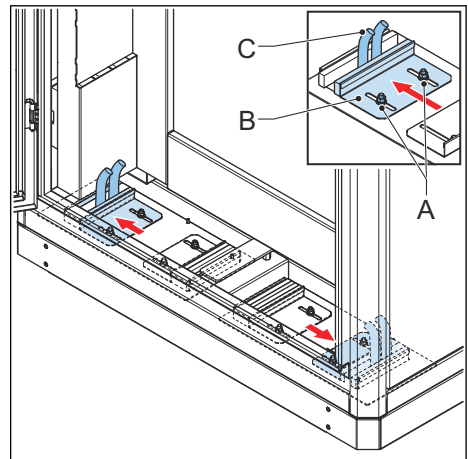

6.2.6

Install the front cover plate (concrete foundation)

Preliminary requirements

	<ul style="list-style-type: none"> • The cabinet is installed on the foundation. 		<ul style="list-style-type: none"> • Four fasteners M10
	<ul style="list-style-type: none"> • Torque wrench 		

Procedure

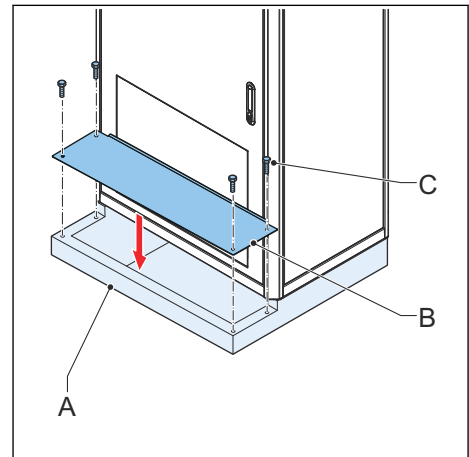

1. Install the cover plate (B) on the foundation (A).
2. Install the fasteners (C).
3. Tighten the fasteners to the correct torque. For the specification, refer to section 12.16.



6.3 Mechanical installation of the charge post

6.3.1 Install the charge post - general procedure

Preliminary requirements

<input checked="" type="checkbox"/>  <input checked="" type="checkbox"/>  <input type="checkbox"/> 	<ul style="list-style-type: none"> • The charge post is above the foundation.
--	--



Warning: Make sure that you secure the load when you do work below the charge post. Obey all related local regulations.





Note: The manufacturer installed the cooling unit at the factory, including the cooling liquid.

Procedure

1. Get access to the charge post:
 - a. Remove the plinth covers of the charge post. Refer to section 10.7.
 - b. Open the door of the charge post. Refer to section 10.6.
 - c. Remove the protection plate of the charge post. Refer to section 10.8.
2. Remove the cable gland plates. Refer to section 6.3.2.
3. Guide the cables through the cable glands. Apply the full cable slack. Refer to section 3.5.6.
4. Install the charge post on the foundation. Refer to section 6.3.3.
5. Install the cable gland plates. Refer to section 6.3.4
6. Close the charge post:
 - a. Install the protection plate of the charge post.
 - b. Close and lock the door of the charge post.
 - c. Install the plinth covers of the charge post.
7. Replace the eye bolts on the charge post with the caps. Refer to section 12.2.

6.3.2 Remove the cable gland plates

Preliminary requirements

	<ul style="list-style-type: none"> • The door is open. • The protection cover is removed. 		<ul style="list-style-type: none"> • Screwdriver, cross • Set of open spanners
---	---	---	--

Procedure

1. Remove these parts:
 - a. Fasteners (A)
 - b. Cable gland plates (B)
 - c. Nuts (C) of the cable glands

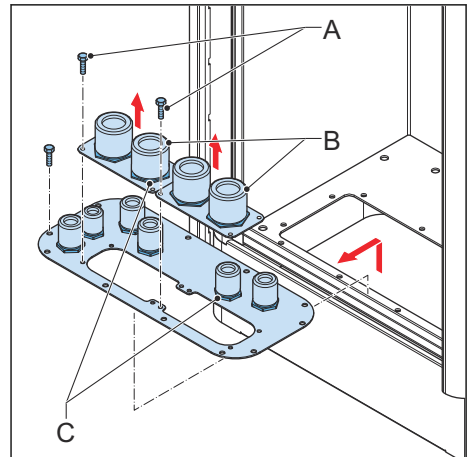

6.3.3 Install the charge post on the foundation

Preliminary requirements

	<ul style="list-style-type: none"> • Hoisting equipment or forklift truck • Torque wrench 		<ul style="list-style-type: none"> • Six fasteners M12 and washers • Drop in anchors, for easy installation and quality
---	---	---	---

Procedure

1. Carefully lower the charge post on the foundation with a hoisting equipment or a forklift truck. Refer to section 12.3.

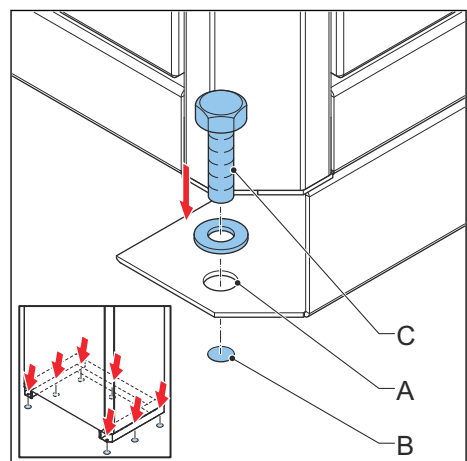

 **Caution:** Make sure that there is no kink in the cables.

2. Make sure that the holes in the charge post (A) and the foundation (B) are aligned.
3. Install the fasteners (C) and the washers.
4. Tighten the fasteners to the correct torque. For the specification, refer to section 12.16.



6.3.4 Install the cable gland plates

Preliminary requirements

	<ul style="list-style-type: none">• The door is open.• The protection cover is removed.		<ul style="list-style-type: none">• Screwdriver, cross• Set of open spanners
---	--	---	---

Procedure

1. Install the nuts (A) of the cable glands over the cables.
2. Install these parts:
 - a. Cable gland plates (B)
 - b. Fasteners (C)
3. Tighten the nuts of the cable glands.

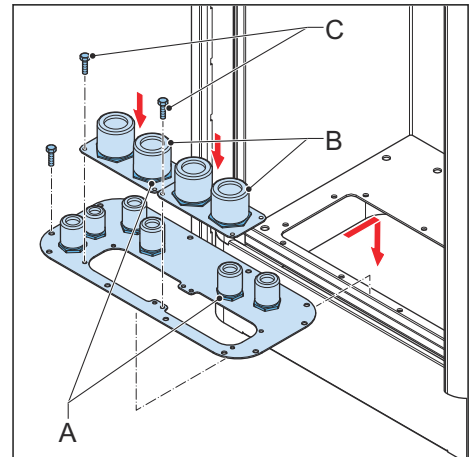





7 Electrical installation of the power cabinet

7.1 General procedure



Note: For a detailed overview of all electrical connections, refer to section 12.23.

Preliminary requirements



<ul style="list-style-type: none"> <input checked="" type="checkbox"/>  <input checked="" type="checkbox"/>  <input type="checkbox"/>  	<ul style="list-style-type: none"> • The DC cables are installed in one of the cable conduits. Refer to section 12.20. • The AC input cable, the PE wire and the communication cables are installed in the other cable conduits. Refer to section 12.20. 		<ul style="list-style-type: none"> • 
--	--	---	---

Procedure

1. Open the door of the power cabinet. Refer to section 10.1.
2. Connect the PE wires to the power cabinet. Refer to section 7.2.
3. Connect the AC input cable.
 - a. Remove the AC covers. Refer to section 10.4.
 - b. Connect the AC input cable. Refer to section 7.4.
 - c. Install the AC covers.
4. Connect the DC power cables.
 - a. Remove the DC busbar cover. Refer to section 10.3.
 - b. Connect the DC power cables. Refer to section 7.3.
 - c. Install the DC busbar cover.
5. Connect these cables:
 - a. AC auxiliary power cable. Refer to section 7.5.
 - b. Interlock and DC guard cables. Refer to section 7.6.
 - c. Optical CAN cable between power cabinet and the charge post. Refer to section 7.7.
6. Connect the control cables for the tilt sensors (option). Refer to section 7.8.
7. Close and lock the door of the power cabinet. Refer to section 10.5.

7.2 Connect the PE cables to the power cabinet

Preliminary requirements

	<ul style="list-style-type: none"> • Torque wrench 		<ul style="list-style-type: none"> • 
---	---	---	---

	<ul style="list-style-type: none"> • Cable lugs. Refer to section 12.4. • Fasteners M12. Refer to section 12.4. 		
---	---	--	--

Procedure

1. Cut the PE cables to make sure that the length is sufficient for connection to the PE busbar (A) with a loop.
The loop is necessary to make sure that the PE cable is not the first cable that is disconnected when a collision moves the power cabinet.

2. Strip the insulation from the end of the cable to the required length. Make sure that the stripped length is compatible with the cable lug (B).
3. Attach the cable lugs to the end of the cables.

4. On the bolt (C), install the toothed washer (D), the cable lug (B) and the contact washer (E).
5. Connect these cables to the busbar:



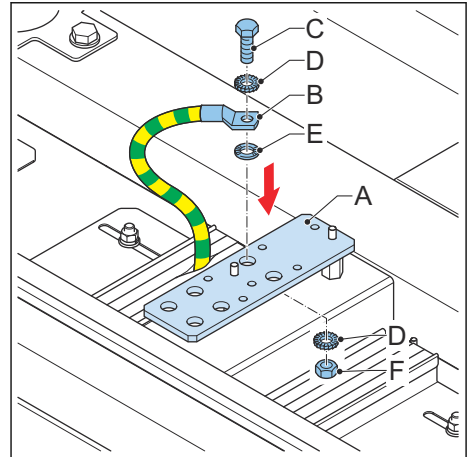

1. PE cable of the AC input cable
2. Cable from the charge post
3. If there is a secondary power cabinet: PE cable from the secondary power cabinets
4. Lightning protection

6. Install a toothed washer (D) and a nut (F) on the bolt (C) from the bottom.
7. Tighten the fasteners to the correct torque. For the specification, refer to section 12.16.



7.3 Connect the DC power cables, static 175 kW system

Preliminary requirements

	<ul style="list-style-type: none"> • Torque wrench • Wire cutter • Wire stripper pliers 		<ul style="list-style-type: none"> • 
	<ul style="list-style-type: none"> • DC power cables (one positive, one negative). Refer to section 12.21.2. • Cable lugs. Refer to section 12.4. 		

Procedure

1. Cut the DC power cables to make sure that the length is sufficient for connection at the DC busbars (A+) and (A-).
2. Install the cable lugs. Refer to section 11.1.
3. Remove the nuts and washers (B) from the bolts of the busbars (A+) and (A-).
4. Connect these cables:
 - DC+ cable (C) to the connector (A+)
 - DC- cable (D) to the connector (A-)
5. Install the nuts and washers on the connector block bolts.
6. Tighten the nuts to the correct torque. For the specification, refer to section 12.16.

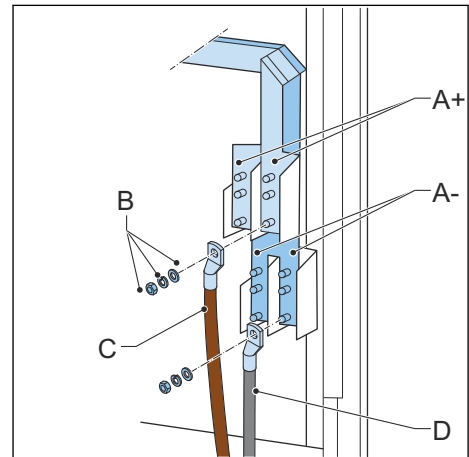

7.4

Connect the AC input cable

Preliminary requirements

	<ul style="list-style-type: none"> • Torque wrench • Wire cutter • Wire stripper pliers 		<ul style="list-style-type: none"> •
	<ul style="list-style-type: none"> • AC input cable. Refer to section 12.21.1. • Cable lugs. Refer to section 12.4. 		

Procedure



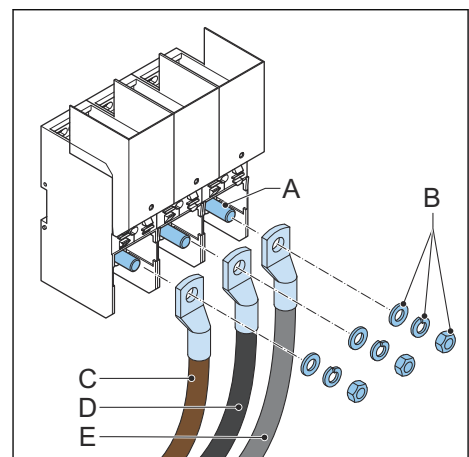

1. Prepare the cables:
 - a. Cut the AC power cables to make sure that the length is sufficient for connection to the busbar bolts (A).
 - b. Strip the insulation from the end of the cables (C), (D), and (E). Make sure that the stripped length is compatible with the cable lug.
2. Remove the nuts and washers (B) from the busbar bolts (A).
3. Attach the cable lugs to the end of the cables.
4. Connect these cables:
 1. L1 (C)
 2. L2 (D)
 3. L3 (E)



5. Install the nuts and washers (B) on the busbar bolts.
6. Tighten the nuts to the correct torque. For the specification, refer to section 12.16.

7.5 Connect the AC auxiliary power cable in the power cabinet

Preliminary requirements

	<ul style="list-style-type: none"> • Torque screwdriver, cross • Wire cutter • Wire stripper pliers • Crimp pliers 		<ul style="list-style-type: none"> • 
	<ul style="list-style-type: none"> • AC auxiliary power cable. Refer to section 12.21.4. • Ferrules 		



Note: The AC auxiliary power cable provides the control power to the charge post.

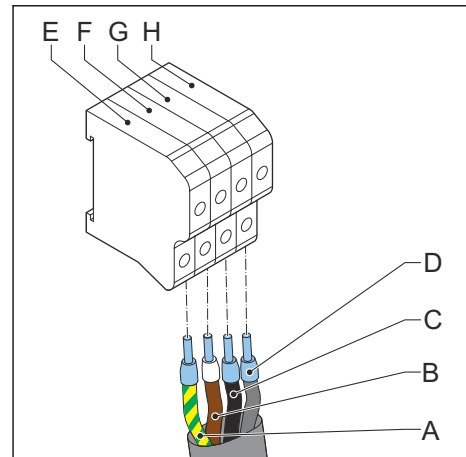

Procedure

1. Strip the insulation from the ends of the wires (A) to (D).
 - For the procedure, refer to section 11.2.
 - For the specification, refer to section 12.21.6.
2. Crimp ferrules onto the end of the wires. Refer to section 11.2.
3. Loosen the screws of the terminal block X-10.
4. Connect these wires:
 - PE wire (A), green/yellow, to the terminal X10-1 (E)
 - L1 wire (B), brown, to the terminal X10-2 (F)
 - L2 wire (C), black, to the terminal X10-3 (G)
 - L3 wire (D), grey, to the terminal X10-4 (H)
5. Tighten the screws to the correct torque. For the specification, refer to section 12.16.



7.6 Connect the interlock and DC guard cables to the power cabinet

Preliminary requirements

	<ul style="list-style-type: none"> Interlock and DC guard cable. Refer to section 12.21.5 Wire loops 		<ul style="list-style-type: none"> 
---	--	---	---



Note: The illustration shows the terminal block X8 on the power cabinet and the connections treated in this section. For a detailed overview of all electrical connections, refer to section 12.21.

Procedure

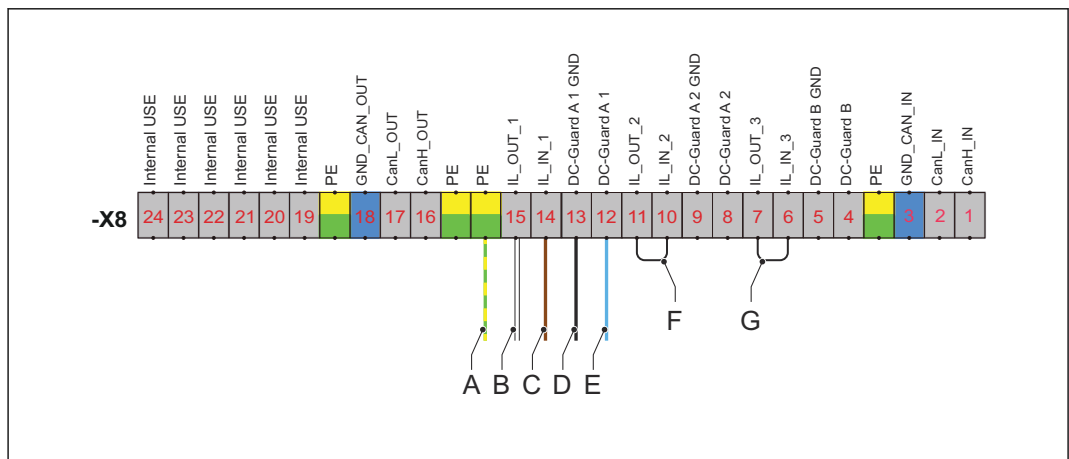

1. Prepare ferrules for the wires that are mentioned below. Refer to section 11.2.
2. Connect these wires from the charge post and use the illustration above as a reference:

Wire from charge post	Connect to terminal	Terminal name
(A) Ground wire or shield mesh	Earthing terminal	PE
(B) Interlock IN	X8-15	IL OUT 1
(C) Interlock OUT	X8-14	IL IN 1
(D) DC guard GND	X8-13	DC guard A1 GND
(E) DC guard signal	X8-12	DC guard A1

3. Connect wire loops:
 - (F) Between the terminals X8-10 and X8-11
 - (G) Between the terminals X8-6 and X8-7

7.7 Connect the optical CAN cables from the charge post to the power cabinet



Note: The Rx and Tx lines must be swapped between the charge the post and the power cabinet.



Note: For a detailed overview of all electrical connections, refer to section 12.23.

Preliminary requirements

	<ul style="list-style-type: none"> Optical CAN cable. Refer to section 12.21.6 Cable tie 		
--	--	--	--

Procedure

1. Guide the optical CAN cables to the fibre-optics converter.
2. Remove the protection covers from the optical connectors.
3. Connect the wires as mentioned in the below table.
 - Use the illustration as a reference.
 - For the optical CAN cable specifications, refer to section 12.21.6.

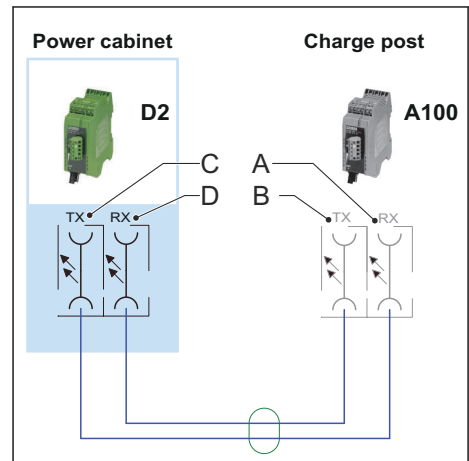

Wire from charge post	Connect to power cabinet
(A) CAN bus fiber cable Rx	(C) connection Tx at D2
(B) CAN bus fiber cable Tx	(D) connection Rx at D2

4. Do not connect the two remaining fiber cables. These fiber cables are spares.
5. Tie the CAN cables together.
 - a. Tighten the loops of the cables with cable ties.
 - b. Make sure that the loop bend radius is sufficient, to prevent damage to the cable core. For the specification, refer to section 12.21.6.

7.8 Connect the control cable for the tilt sensors to the power cabinet (option)

Preliminary requirements

	<ul style="list-style-type: none"> • Torque screwdriver, cross • Wire cutter • Wire stripper pliers • Crimp pliers 		<ul style="list-style-type: none"> • Control cable for the tilt sensors. Refer to section 12.21.7. • Ferrules
---	--	--	---

Procedure

1. Strip the insulation from the ends of the wires (A) to (H). For the specification, refer to section 12.21.7.
2. Crimp ferrules onto the end of the wires.
3. Loosen the screws of the terminal block X-1.
4. Connect these wires:
 - V^+ wire (A) from the external customer interface, wire number 1, to the terminal X1-1 (I)
 - V^- wire (C) from the external customer interface, wire number 2, to the terminal X1-3 (K)
 - R_{in} wire (E) from the external customer interface, wire number 3, to the terminal X1-5 (M)
 - R_{out} wire (G) from the external customer interface, wire number 4, to the terminal X1-7 (O)
5. Tighten the screws to the correct torque. For the specification, refer to section 12.16.

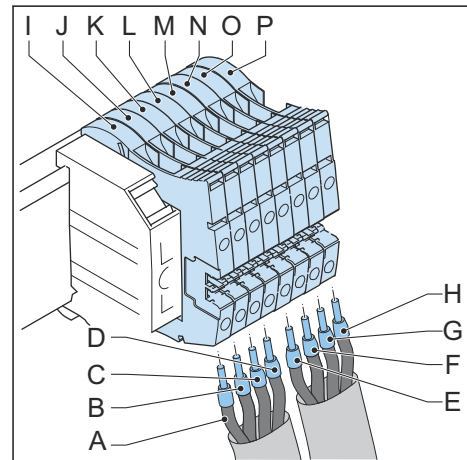

8 Electrical installation of the charge post

8.1 General procedure



Note: For a detailed overview of all electrical connections, refer to section 12.23.

Preliminary requirements

	<ul style="list-style-type: none"> All cables are installed in the cable conduits. Refer to section 12.20. 		<ul style="list-style-type: none">
--	---	--	--

Procedure

1. Open the door of the charge post. Refer to section 10.6.
2. Remove the protection plate. Refer to section 10.8.
3. Connect the cables to the charge post:
 - PE wire. Refer to section 8.2
 - DC power cable. Refer to section 8.3
 - AC auxiliary power cable. Refer to section 8.4.
 - Interlock and DC guard cable. Refer to section 8.5
 - Optical CAN cable from the power cabinet. Refer to section 8.6
 - Control cables for the tilt sensor (option). Refer to section 8.8.
 - Ethernet cable. Refer to section 8.7.
4. Install the protection plate.
5. Close and lock the door of the charge post. Refer to section 10.9.

8.2 Connect the PE wire

Preliminary requirements

	<ul style="list-style-type: none"> The door is open. 		<ul style="list-style-type: none"> Cable lug. Refer to section 12.4. Fasteners M11. Refer to section 12.4.
	<ul style="list-style-type: none"> Wire stripper pliers Wire cutter Torque wrench 		<ul style="list-style-type: none">

Procedure

1. Prepare the wire:
 - a. Cut the PE wire (A) to make sure that the length is sufficient for connection at the PE busbar (B) with a loop.
 The loop is necessary to make sure that the PE wire is not the first wire that is disconnected when a collision moves the charge post.
 - b. Strip the insulation from the end of the wire. Make sure that the stripped length is compatible with the cable lug specification.
 - c. Attach the cable lug (C) to the end of the wire.
2. Attach the PE wire to the PE busbar.
 Use the fasteners (D).
3. Tighten the fasteners to the correct torque. For the specification, refer to section 12.16.

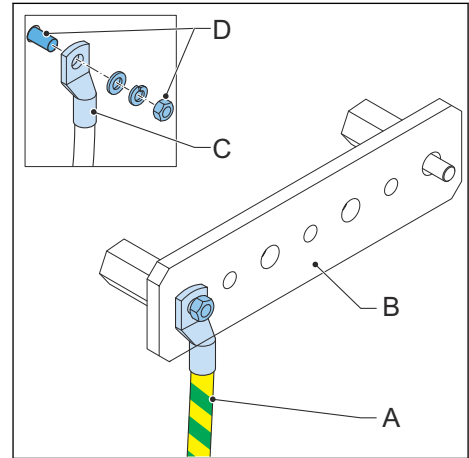

8.3 Connect the DC power input cables

Preliminary requirements

	<ul style="list-style-type: none"> • Wire cutter • Wire stripper pliers • Spanner • Torque wrench • Torque screwdriver, cross 		
	<ul style="list-style-type: none"> • DC power cable. Refer to section 12.21.2. • Cable lugs. Refer to section 12.4. 		

Procedure



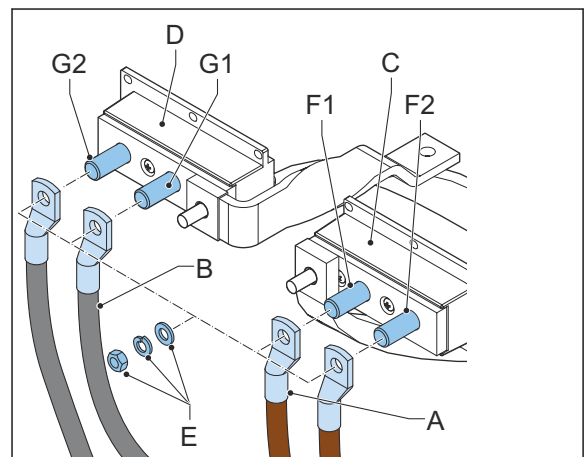

1. Cut the DC power cables (A) and (B) to make sure that the length is sufficient for connection at the DC busbars (C) and (D).
2. Strip the insulation from the end of the cables. Make sure that the strip length is compatible with the cable lugs.
3. Attach the cable lugs to the end of the cables.
4. Remove the nuts and washers (E) from the connector bolts (F1) and (G1) of the DC busbars.



5. Connect these cables:
 - DC+ cable (A) to the connector bolt (F1).
 - DC- cable (B) to the connector bolt (G1).
6. If you need to connect more DC cables, do steps 4 and 5 again for the other wires and connector bolts (F2) and (G2).
7. Install the nuts and washers on the connector bolts of the DC busbars.
8. Tighten the nuts to the correct torque. For the specification, refer to section 12.16.

8.4 Connect the AC auxiliary power cable

Preliminary requirements

	<ul style="list-style-type: none"> • Wire cutter • Wire stripper pliers • Torque screwdriver, cross • Crimp pliers 		<ul style="list-style-type: none"> • 
	<ul style="list-style-type: none"> • AC auxiliary power cable • Ferrules 		



Note: The AC auxiliary power cable provides the control power to the charge post.

Procedure

1. Strip the insulation from the ends of the wires (A) to (D). For the specification, refer to section 12.21.4.
2. Crimp ferrules onto the end of the wires.
3. Loosen the screws of the terminals (E) to (H) of the terminal block X-10.
4. Connect these wires:
 - PE wire (A), green/yellow, to the terminal X10-1 (E)
 - L1 wire (B), brown, to the terminal X10-2 (F)
 - L2 wire (C), black, to the terminal X10-3 (G)
 - L3 wire (D), grey, to the terminal X10-4 (H)
5. Tighten the screws to the correct torque. For the specification, refer to section 12.16.

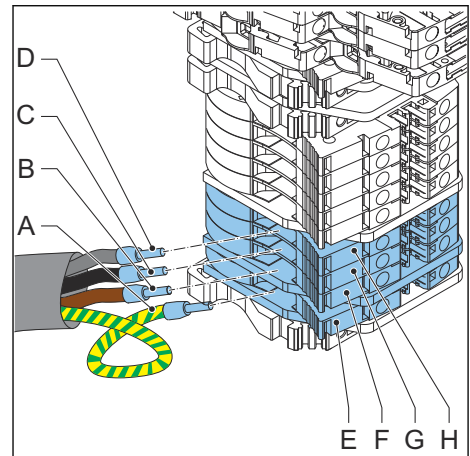





8.5

Connect the interlock and DC guard cable



Note: For a detailed overview of all electrical connections, refer to section 12.23.

Preliminary requirements

	<ul style="list-style-type: none"> • Torque screwdriver, cross 		<ul style="list-style-type: none"> • 
	<ul style="list-style-type: none"> • Interlock and DC guard cable. Refer to section 12.21.5. • Ferrules 		

Procedure

 **Note:** The illustration shows the terminal block X20 of the charge post and the connections treated in this section.

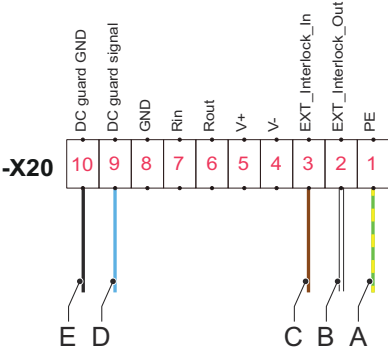

1. Prepare ferrules for the wires that are mentioned below. Refer to section 11.2.
2. Connect these wires from the power cabinet:

Wires from the power cabinet	Connect to terminal	Terminal name
(A) Ground wire or shield mesh	X20-1	PE
(B) IL IN 1	X20-2	Interlock OUT
(C) IL OUT 1	X20-3	Interlock IN
(D) DC guard A1	X20-9	DC guard signal
(E) DC guard A1 GND	X20-10	DC guard GND

 **Note:** The colors of the cables can be different in your equipment. The colors in the illustration are used to clarify the explanation and to distinguish the different cables.

8.6 Connect the optical CAN cable

 **Note:** The Rx and Tx lines must be swapped between the charge the post and the power cabinet.



Note: For a detailed overview of all electrical connections, refer to section 12.23.

Preliminary requirements

	<ul style="list-style-type: none"> Optical CAN cable. Refer to section 12.21.6 Cable tie 		<ul style="list-style-type: none">
--	--	--	--

Procedure

1. Guide the optical CAN cables to the fibre-optics converter.
2. Remove the protection covers from the optical connectors.
3. Connect these wires:
 - Use the illustration as a reference.
 - For the optical CAN cable specifications, refer to section 12.21.6.

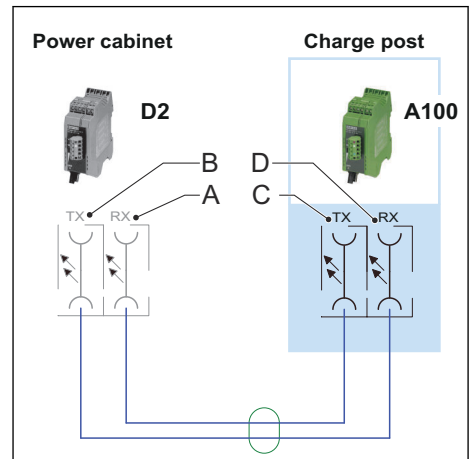

Wire from power cabinet	Connect to charge post
(A) CAN bus fiber cable Rx	(C) connection Tx at A100
(B) CAN bus fiber cable Tx	(D) connection Rx at A100

4. Do not connect the two remaining fiber cables. These fiber cables are spares.
5. Tie the CAN cables together.
 - a. Tighten the loops of the cables with cable ties.
 - b. Make sure that the loop bend radius is sufficient, to prevent damage to the cable core. For the specification, refer to section 12.21.6.

8.7 Connect the Ethernet cable

Preliminary requirements

	<ul style="list-style-type: none"> Ethernet cable with an RJ45 plug. Refer to section 12.21.8
--	--



Note: Daisy chaining is not supported for Ethernet.

Procedure

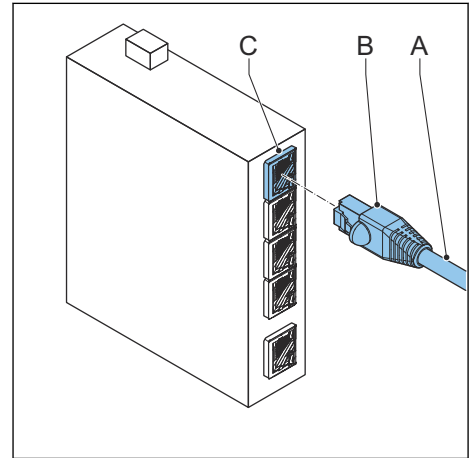

1. Guide the cable (A) to the switch ethernet device (B).
2. Connect the RJ45 plug to the switch port X1 (C).



8.8

Connect the control cable for the tilt sensors from the external customer interface to the charge post (option)

Preliminary requirements

	<ul style="list-style-type: none"> • Torque screwdriver, cross • Wire cutter • Wire stripper pliers • Crimp pliers 		<ul style="list-style-type: none"> • Control cable for the tilt sensors. Refer to section 12.21.7. • Ferrules
---	--	---	---

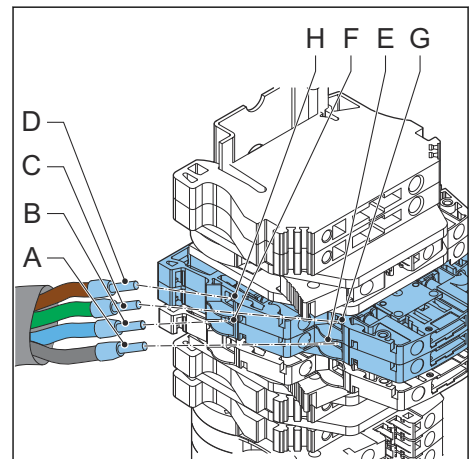

Procedure

1. Strip the insulation from the ends of the wires (A) to (D). For the specification, refer to section 12.21.7.
2. Crimp ferrules onto the end of the wires.
3. Loosen the screws of the terminal block X-20.
4. Connect these wires:
 - *V-* wire (A), grey, to the terminal X-20-4 (E)
 - *V+* wire (B), blue, to the terminal X-20-5 (F)
 - *Rin* wire (C), green, to the terminal X-20-7 (H)
 - *Rout* wire (D), brown, to the terminal X-20-6 (G)
5. Tighten the screws to the correct torque. For the specification, refer to section 12.16.



9 Prepare for commissioning

Preliminary requirements

	<ul style="list-style-type: none"> Qualified installation engineer
---	---



Danger:

Hazardous voltage

- Do not commission the EVSE. Only a service engineer of the manufacturer is qualified to commission the EVSE.

Procedure

1. Tell the owner that the EVSE is ready for commissioning.
2. Make sure that the site complies with these requirements:
 - The EVSE is installed.
 - AC input power is available from the grid provider.
 - You are present during the commissioning, for assistance and to energize the power to the EVSE on the power distribution board.
 - Internet access is available, through 2G/3G/4G or through a wired Ethernet connection.
 - An EV must be available with a compatible connection. If the EVSE has more than one connection type, an EV of each type must be available.
 - The site operator or owner is available to receive instructions from the service engineer of the manufacturer.
3. Make sure that this data is available:
 - Contact data of the contact person on site
 - Address of the EVSE
 - Site name
 - Exact location of the EVSE: longitude and latitude. If there are more EVSEs on one location, make sure that the coordinates are slightly different (at least 0.0001 degree) so that the EVSEs are not at the same location on the map.
 - Specification of the external fuse at the power distribution board
 - Date that the installation is done
 - Special remarks, for example to decline the authorization for the service engineer of the manufacturer to take photos
 - Photo of the surroundings of the EVSE

10 Access to parts

10.1 Open the door of the power cabinet

Preliminary requirements

	<ul style="list-style-type: none"> • Door key of the power cabinet
---	---



Danger:

Hazardous voltage

- Make sure that only qualified personnel has access to the door key.



Note: There is one unique door key for each power cabinet.

Procedure

1. Turn the cover plate (A).
2. Insert the door key (B).
3. Turn the door key counterclockwise to unlock the door (C).
4. Pull the handle (D).
5. Turn the handle clockwise.
6. Open the door.

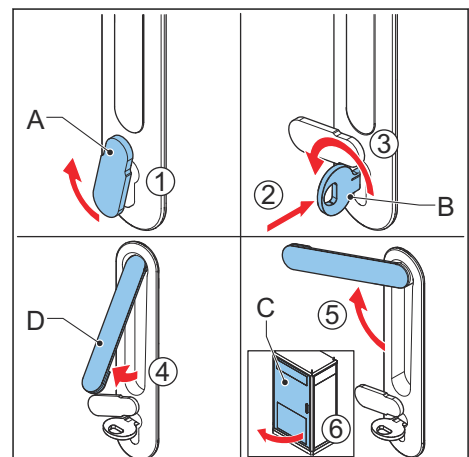

10.2 Remove the plinth covers of the power cabinet

Preliminary requirements

	<ul style="list-style-type: none"> • Screwdriver, cross
---	--

Procedure

1. Remove these parts:
 - Fasteners (A)
 - Plinth covers (B)

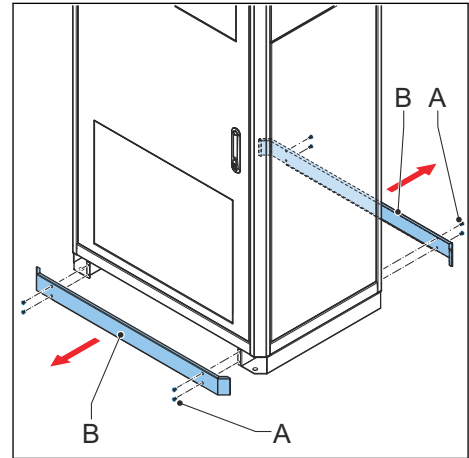

10.3 Remove the DC busbar cover

Preliminary requirements

	<ul style="list-style-type: none">• Screwdriver, cross
--	--

Procedure

1. Remove the fasteners (A).
2. Remove the cover (B).

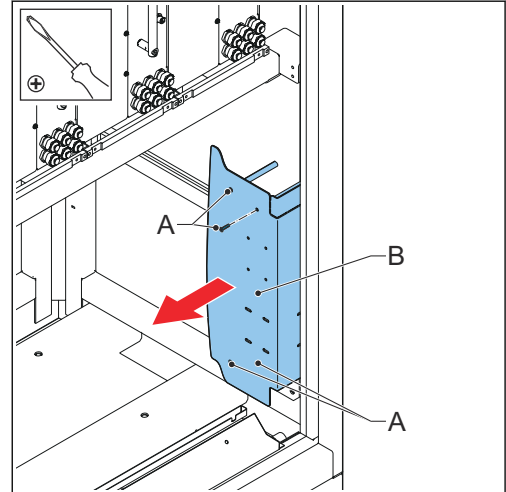

10.4 Remove the AC covers

Preliminary requirements

	<ul style="list-style-type: none">• Screwdriver, cross
---	--

Procedure

1. Remove these parts:
 - Fasteners (A)
 - Cover (B)
 - Cover (C)

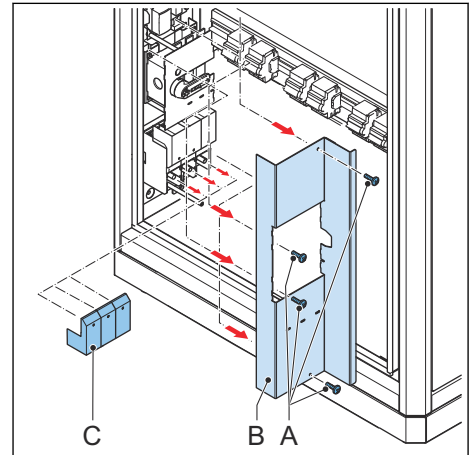

10.5 Close the door of the power cabinet

Preliminary requirements

	<ul style="list-style-type: none"> • Door key to the power cabinet.
--	--



Danger:

Hazardous voltage

- Make sure that only qualified personnel has access to the door key.



Note: There is one unique door key for each cabinet.

Procedure

1. Close the door (A).
2. Turn the handle (B) counterclockwise.
3. Push the handle.
4. Turn the door key (C) clockwise to lock the door.
5. Remove the door key (C).
6. Turn the cover plate (D) to cover the keyhole.

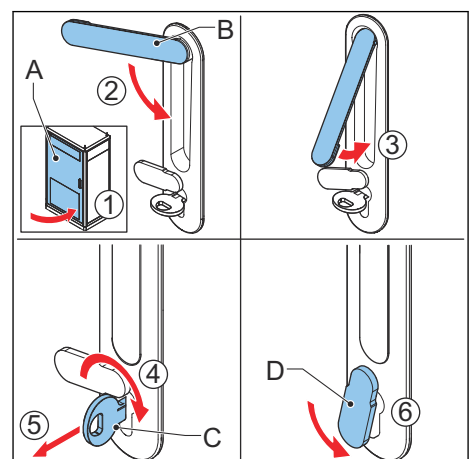

10.6 Open the door of the charge post

Preliminary requirements

	<ul style="list-style-type: none">• Door key of the charge post
---	---



Danger:

Hazardous voltage

- Make sure that only qualified personnel has access to the door key.



Note:

- There is one unique door key for each charge post.
- The door of the charge post is under some pressure, to make sure that it closes watertight.

Procedure

1. Insert the door key (A).
2. Turn the door key counterclockwise to unlock the door (B).
3. Pull the handle (C).
4. Turn the handle clockwise.
5. Open the door.

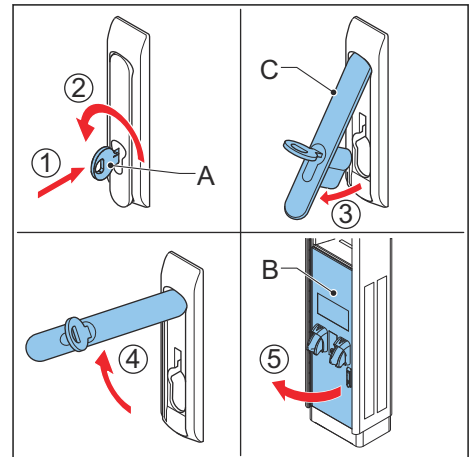

10.7 Remove the plinth covers of the charge post

Preliminary requirements

	<ul style="list-style-type: none">• Set of hex keys
---	---

Procedure

1. Remove these parts:
 - Fasteners (A)
 - Plinth covers (B)

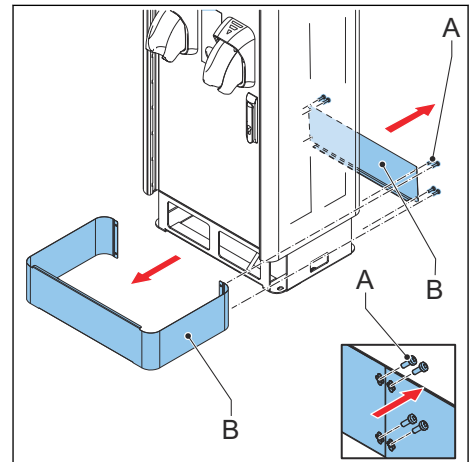

10.8 Remove the protection plate of the charge post

Preliminary requirements

	<ul style="list-style-type: none"> • Screwdriver, cross
--	--

Procedure

1. Remove these parts:
 - Fasteners (A)
 - Protection plate (B)

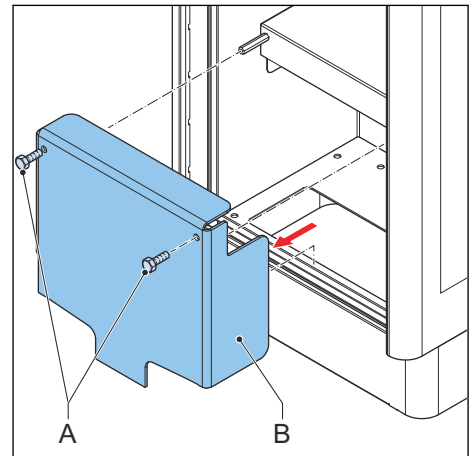

10.9 Close the door of the charge post

Preliminary requirements

	<ul style="list-style-type: none"> • Door key of the charge post
---	---



Danger:

- **Hazardous voltage**
- Make sure that only qualified personnel has access to the door key.



Note: There is one unique door key for each charge post.

Procedure



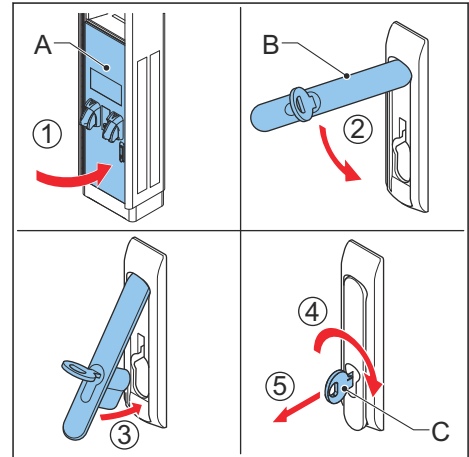

1. Close the door (A).
2. Turn the handle (B) counterclockwise.
3. Push the handle.
4. Turn the door key (C) clockwise to lock the door.
5. Remove the door key.



11 Generic procedures

11.1 Install a cable lug on a wire

Preliminary requirements

	<ul style="list-style-type: none"> • Wire cutter • Wire stripper pliers • Crimp plier 		<ul style="list-style-type: none"> • 
	<ul style="list-style-type: none"> • Cable lug 		



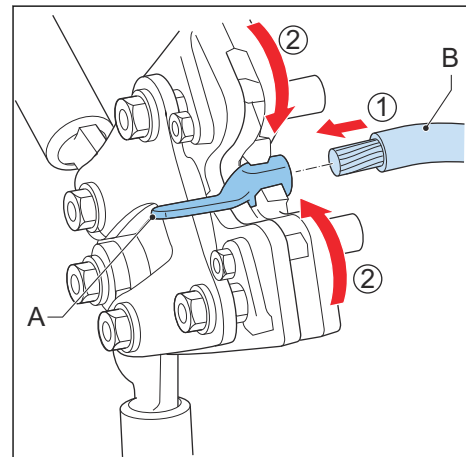

Procedure

1. Make sure that the diameter of the cable lug is correct. The cable lug must be compatible with the wire.
2. Strip the insulation from the wire. The stripped length must be the same as the length of the cavity of the cable lug.
3. Insert the conductor of the wire into the cavity of the cable lug.
4. Install the cable lug on the wire. Use the crimp plier.



11.2 Install a ferrule on a wire

Preliminary requirements

	<ul style="list-style-type: none"> • Wire cutter • Wire stripper pliers • Crimp plier 		<ul style="list-style-type: none"> • 
	<ul style="list-style-type: none"> • Ferrule 		

Procedure

1. Make sure that the diameter of the ferrule is correct. The ferrule must be compatible with the wire. Obey the technical specifications set by the manufacturer. Refer to section 12.21.
2. Strip the insulation from the wire. The stripped length must be the same as the length of the cavity of the ferrule. For the specifications, refer to section 12.4.
3. Put the ferrule in the crimp plier.
4. Insert the wire into the cavity of the ferrule.
5. Install the ferrule on the wire. Use the crimp plier.

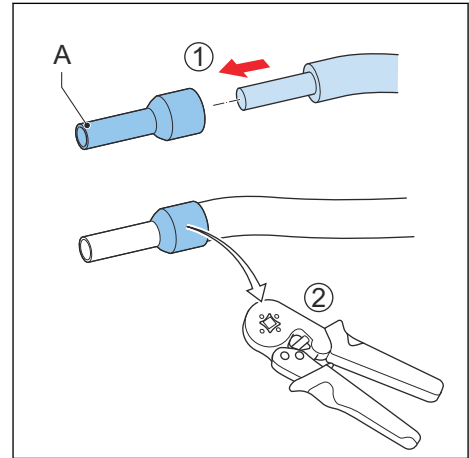

11.3 Install insulating heatshrink tubing on a wire

Preliminary requirements

	<ul style="list-style-type: none"> • Heat gun 		<ul style="list-style-type: none"> • 
	<ul style="list-style-type: none"> • Heatshrink tubing 		

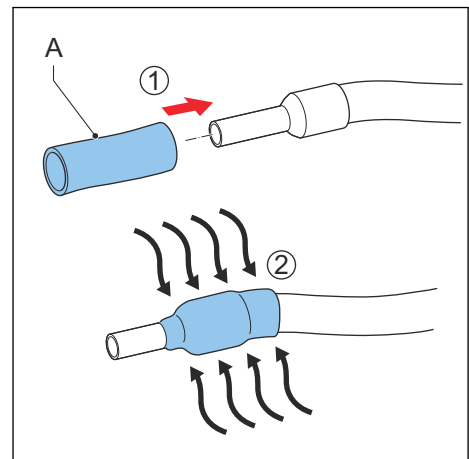

Procedure

1. Clean the part of the wire, or the wire with the cable lug, that you want to insulate.
2. Cut a piece of heatshrink tubing.
 - Make sure that the length covers all electrical cables.
 - Use a diameter that is larger than the wire diameter.
3. Install the piece of heatshrink tubing on the wire or the wire with the cable lug.
4. Shrink the heatshrink tubing on the wire. Use the heat gun. Make sure that you shrink the heatshrink tubing evenly on all sides.



11.4 Connect a wire that has a cable lug

Preliminary requirements

	<ul style="list-style-type: none"> • Torque screwdriver, cross 		<ul style="list-style-type: none"> • 
---	---	---	---

Procedure

1. Loosen the bolt of the connection pin (A) on the busbar (B).
2. Install the eye of the cable lug (C) on the connection pin.
3. Tighten the bolt of the connection pin on the busbar to the correct torque. For the torque specification, refer to section 12.16.
4. Make sure that unused wires are protected and cannot touch metal parts.

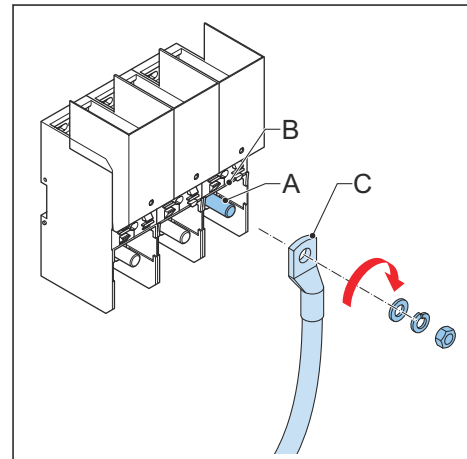

11.5 Connect a wire that has a ferrule

Preliminary requirements

	<ul style="list-style-type: none"> • 
---	---

Procedure

1. Loosen the screw of the connection on the terminal.
2. Install the ferrule in the connection of the terminal.
3. Tighten the screw to the correct torque. For the specifications, refer to section 12.16.
4. Make sure that unused wires are protected and cannot touch metal parts.

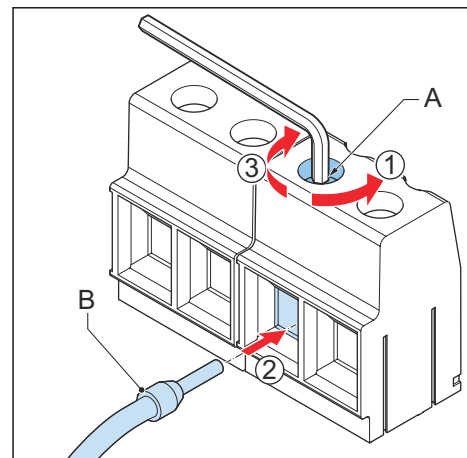

12 Technical data

12.1 EVSE type

The EVSE type is a code, mentioned on the type plate. Refer to section 3.2.
The code is made out of 3 parts: T U V

Code part	Description	Value	Meaning of the value
T	Model	HP	Terra high power
U	Part	CP500	Charge post, 500 A DC output
		-	Power cabinet
V	EV charge cable connection, in the case of a charge post	C	One CCS connection
		CC	Two CCS connections
		CJ	One CCS connection and one CHAdeMO connection
	Peak output power, in the case of a power cabinet	175	Peak output power [kW]

Examples

HP CP500 C:

- T = HP, Model = Terra high power
- U = CP500, Part = charge post 500 A DC output
- V = C, EV charge cable connection = one CCS connection

HP 175:

- T = HP, Model = Terra high power
- U = Part = power cabinet
- V = 175, peak output power is 175 kW

12.2 Parts included in the delivery

Parameter	Specification
Charge post	Refer to the type plate. Refer to section 3.2.
Power cabinet	Refer to the type plate. Refer to section 3.2.
Door keys	Door keys for the power cabinet and the charge post
Eye bolts to hoist the power cabinet	M16, 63 mm (2.5 in)
Caps to replace the eye bolts after transport of the power cabinet	To fit in the holes for the eye bolts

Parameter	Specification
Eye bolts to hoist the charge post	M10, 45 mm (1 3/8 in)
Caps to replace the eye bolts after transport of the charge post	To fit in the holes for the eye bolts



Note: It is possible that more parts are required in the delivery. Refer to the order.

12.3

Required tools for installation

Parameter	Specification
Hoisting equipment or forklift truck	Capable to lift the EVSE safely. Take into account the dimensions, the mass, and the center of gravity.
Swivel eye bolts or bolts with lifting loops (to use with hoisting equipment) As a standard, eye bolts are installed on the cabinets. Refer to section 12.2.	Thread M10 for the charge post Thread M16 for the power cabinet
Bolts	Size M16
Hex keys	Standard set of hex keys
Open spanners	Standard set of open spanners
Torque socket wrench	For the torque specifications, refer to section 12.16.
Screwdriver, cross	Size M5 (8 mm (0.3 in))
Wire cutter	-
Wire stripper pliers	-
Crimp pliers	-

12.4

Required parts for installation

Part	Specification
Fasteners and washers, to connect the charge post to the foundation	M12, class A2, length 70 mm (2.75 in)
Fasteners and washers, to connect the power cabinet to the foundation	M16, class A2, length 70 mm (2.75 in)
Fasteners and washers, for the earthing connections	M11, class A2, length 70 mm (2.75 in)

Table 1: Cable lugs

Location	Wire	Size	Maximum width		Maximum length	
			[mm]	[in]	[mm]	[in]
Power cabinet	PE	M12	35	1.4	70	2.7
		M10	25	70	50	70

Location	Wire	Size	Maximum width		Maximum length	
			[mm]	[in]	[mm]	[in]
		M6	12	0.5	40	1.6
	AC input power	M12	39	1.5	70	2.7
	DC power	M12	39	1.5	70	2.7
Charge post	PE	M8	22	0.9	40	1.6
		M6	12	0.5	40	1.6
	DC power	M12	39	1.5	40	1.6

12.5 Transport specifications

Parameter	Specification
Maximum tilt angle during transport	15°

12.6 General specifications

Parameter	Specification
Compliance and safety	CE
Ingress protection rating	IP54

Parameter	Specification
EMC rating for the charge post	<p>The charge post complies with these standards:</p> <ul style="list-style-type: none"> EN 61000-6-3 : 2007 + A1: 2001 Emission standard for residential, commercial and light-industrial environments (Class B) EN 61000-6-2 : 2005 Immunity for industrial environments EN 301489-1 V2.2.0 : 2017 <p>The charge post also complies with the less strict requirements in these standards:</p> <ul style="list-style-type: none"> EN 61000-6-4: 2007 + A1: 2011 Emission standard for industrial environments (Class A) EN 61000-6-1 : 2007 Immunity for residential, commercial and light-industrial environments
EMC rating for the power cabinet	<p>The power cabinet complies with these standards:</p> <ul style="list-style-type: none"> EN 61000-6-4:2007 + A1 Emission standard for industrial environments (Class A) EN 61000-6-2: 2005 Immunity for industrial environments <p>If the power cabinet must comply with Class B (residential), install an external EMC filter: Schaffner type FN 3359HV-400-99. To order this part, give the global ID: 6AGC079955. When this external EMC filter is installed, the power cabinet complies with this standard:</p> <ul style="list-style-type: none"> EN 61000-6-3 : 2007 + A1 2011 Emission standard for residential, commercial and light-industrial environments (Class B)

12.7

Electrical installation specifications (Europe)

Parameter	Specification
Circuit breaker	Use a circuit breaker with the option for an under voltage release device. For example, refer to TMAX XT5 320 A tuned according to type C or similar.
Surge protection device	Type 2

Parameter	Specification
Residual-current device	In the range of 30 mA up to 300 mA The power cabinet has an integrated 300 mA RCD (Type A) for the power section.
Power consumption of the power cabinet	In standby status: ≤ 80 W
Power consumption of the charge post	In standby status: ≤ 70 W With the LEDs on: ≤ 145 W
Earthing system	TN-C
	TN-S
	TN-CS
	TT
Input AC power connection	400/230 VAC 3W + PE
Input voltage range	400 V AC +/- 10% (50 Hz or 60 Hz)
Nominal input current	277 A at 400 V AC
Maximum input current	308 A at 360 V AC
Power factor at full load	> 0.97
Efficiency	≥ 94% at ≥ 20 % load
Short circuit capacity	25 kA

12.8 Input current unbalance

To select the correct rating of the upstream MCB (miniature circuit breaker) or fuse protection, the power quality must be evaluated. This prevents unexpected security intervention.

In the event that the grid provider supplies an unbalanced voltage network - there is a homopolar component - the power cabinet will have an imbalance of current compared to the ideal conditions.

The sum of the 3-phase input currents must remain constant ($I_{ph1}+I_{ph2}+I_{ph3}$). The table below shows the maximum percentage of possible current variation that one phase can have from the ideal conditions at different voltage unbalance:

Voltage unbalance	Maximum allowed current variation
0%	0.1%
0.5%	1.4%
1%	4.8%
1.5%	6.3%
2%	7.8%



Note: If the ideal current of each phase is 274 A, but the voltage unbalance is 2%, the current of one phase will be up to 295 A. Consider this current when you select the upstream over current protection.



Caution: The maximum for input current unbalance is 2%. The EVSE will only perform according to its datasheet when supply grid voltage obeys this maximum unbalance.

12.9 DC output specifications

Parameter	Specification
Output voltage range	150 - 920 V DC
Maximum output current	375 A DC (one power cabinet) 500 A DC (two power cabinets)
Output power	175 kW up to 40 °C (104 °F) - one power cabinet 350 kW up to 40 °C (104 °F) - two power cabinets
DC output current	500 A CCS (liquid cooled) 200 A CHAdeMO

12.10 Logic interfaces specifications

Parameter	Specification
RFID standard	ISO/IEC 14443A/B, ISO/IEC 15393
RFID supported applications	FeliCa™1, NFC, Mifare, Calypso
Network connection	4G, 3G, 2G, Ethernet

12.11 Current peaks during the start of a charge session (DC output)

Parameter	Specification
Duration of the current peaks	25 μs
Maximum current peak	60 A

12.12 Mass and center of gravity

12.12.1 Mass

Parameter	Specification	
	[kg]	[lbs]
Mass of the power cabinet	850	1874
Mass of the charge post	250	551.2

12.12.2 Center of gravity, power cabinet

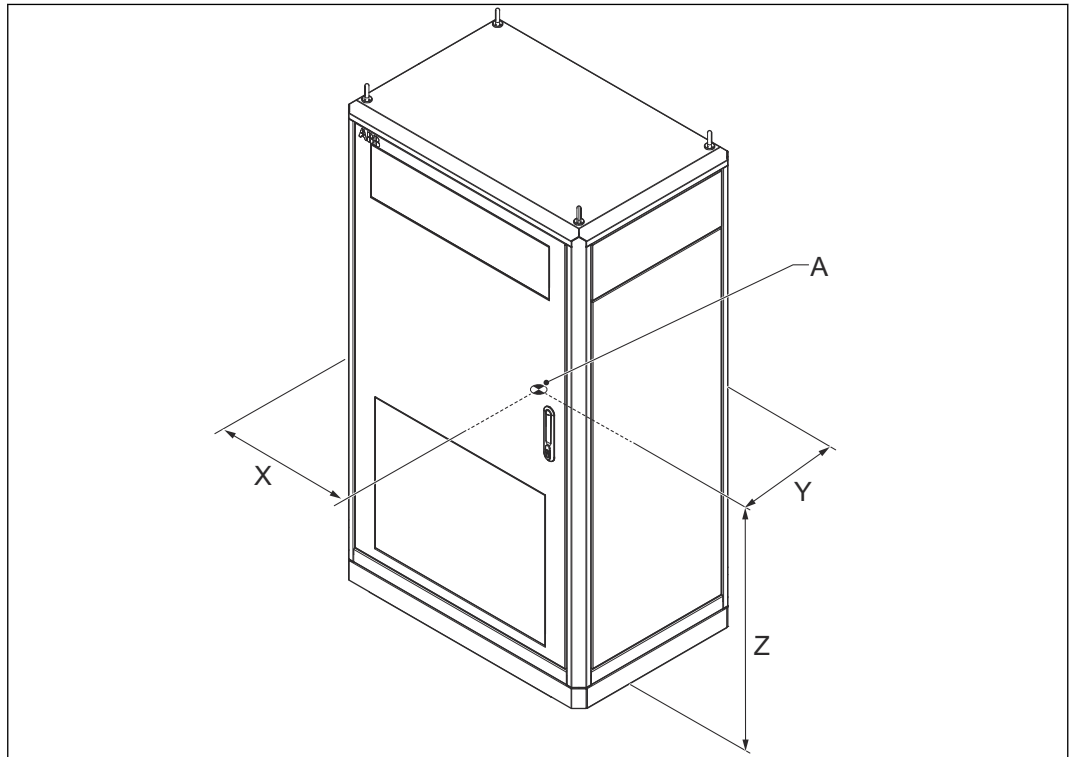

A Center of gravity

Parameter	Specification	
	[mm]	[in]
X	587	23.1
Y	407	16.0
Z	1068	42.1

12.12.3 Center of gravity, charge post

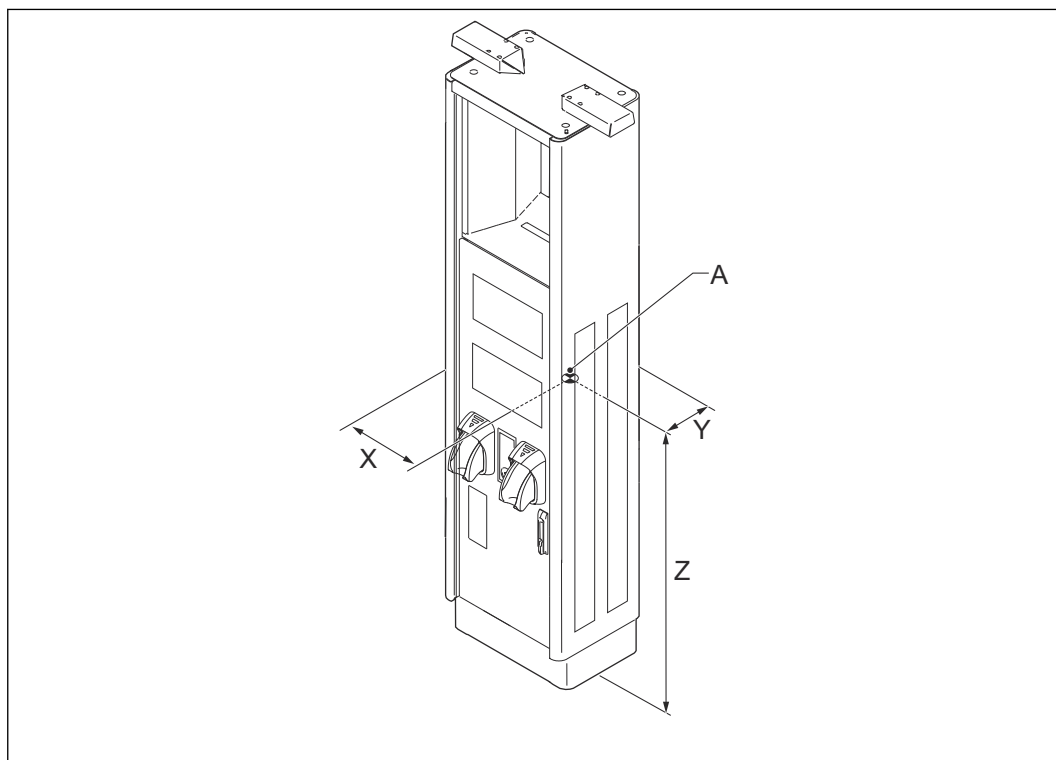

A Center of gravity

Parameter	Specification	
	[mm]	[in]
X	353	13.9
Y	244	9.6
Z	1096	43.2

12.13 Tilt sensor specifications (option)

Parameter	Specification
Tilt to disable the power from the low voltage source	> 10°

12.14 Ambient conditions

Parameter	Specification
Operation temperature	-35 °C to +55 °C (-31 °F to +131 °F) Derating applies
Storage	+5 °C to +40 °C (+41 °F to 104 °F) RH 5 to 85%
Environment	IP54, rainproof

Parameter	Specification
	IK10 (screen: IK08)
Altitude	Maximum 2000 m (6562 ft) above the sea level

12.15 Noise level

Noise level	Specification [dB(A)]
Charge post, 500 A continuous up to 35 °C	≤ 60 at 1 m (39.4 in)
Maximum noise level of the charge post	68 at 1 m (39.4 in)
Power cabinet	≤ 65 at 1 m (39.4 in)

12.16 Torque specifications

Parameter	Specification	
	[Nm]	[lb-in]
Power cabinet, fasteners to the foundation	80	708
Power cabinet, nuts on the PE busbars	30	266
Power cabinet, nuts on the AC power busbars	30	266
Power cabinet, screws in the terminal blocks	1.3	11.5
Power cabinet, nuts on the DC power busbars	30	266
Charge post, fasteners to the foundation	80	708
Charge post, fasteners on the PE busbar	Between 33 and 44	Between 292 and 389
Charge post, screws in the terminal blocks	1.3	11.5
DC input cable to the connector	30	265.5
M5 fasteners (if not specified)	3.5	31.0
M6 fasteners (if not specified)	9	79.7
M8 fasteners (if not specified)	20	177
M10 fasteners (if not specified)	40	354
M12 fasteners (if not specified)	70	619.5
M16 fasteners (if not specified)	180	1593

12.17 Dimensions

12.17.1 Power cabinet

Parameter	Specification	
	[mm]	[in]
Width (X-dimension)	1170	46.1
Depth (Y-dimension)	770	30.3
Height (Z-dimension)	2030	30.3
Required cable slack for the AC input cable (measured from the top of the foundation)	1000	39.4
Required cable slack for the PE cable (measured from the top of the foundation)	2000	78.7
Required cable slack for the DC output cable (measured from the top of the foundation)	2000	78.7
Required cable slack for the AC auxiliary power cable (measured from the top of the foundation)	2000	78.7
Required cable slack for the interlock and DC guard, and CAN cables (measured from the top of the foundation)	2000	78.7

12.17.2 Charge post

Parameter	Specification	
	[mm]	[in]
Width of the charge post (X-dimension)	590	23.2
Depth of the charge post (Y-dimension)	425	16.7
Height of the charge post (Z-dimension)	2463	97.0
Required cable slack for the PE wire (measured from the top of the foundation)	700	27.6
Required cable slack for the DC power cables (measured from the top of the foundation)	700	27.6
Required cable slack for the AC auxiliary power cable (measured from the top of the foundation)	1200	47.2
Required cable slack for the interlock and DC guard cable (measured from the top of the foundation)	1200	47.2

Parameter	Specification	
	[mm]	[in]
Required cable slack for the CAN cable (measured from the top of the foundation)	1200	47.2
Required cable slack for the tilt sensor control cable (measured from the top of the foundation), if applicable	1200	47.2

Parameter	Specification	
	[m]	[ft]
Length of the charge cable, with retraction system	5.3	9.8
Cable reach, approximately	3	118

12.17.3 Height of user operable elements

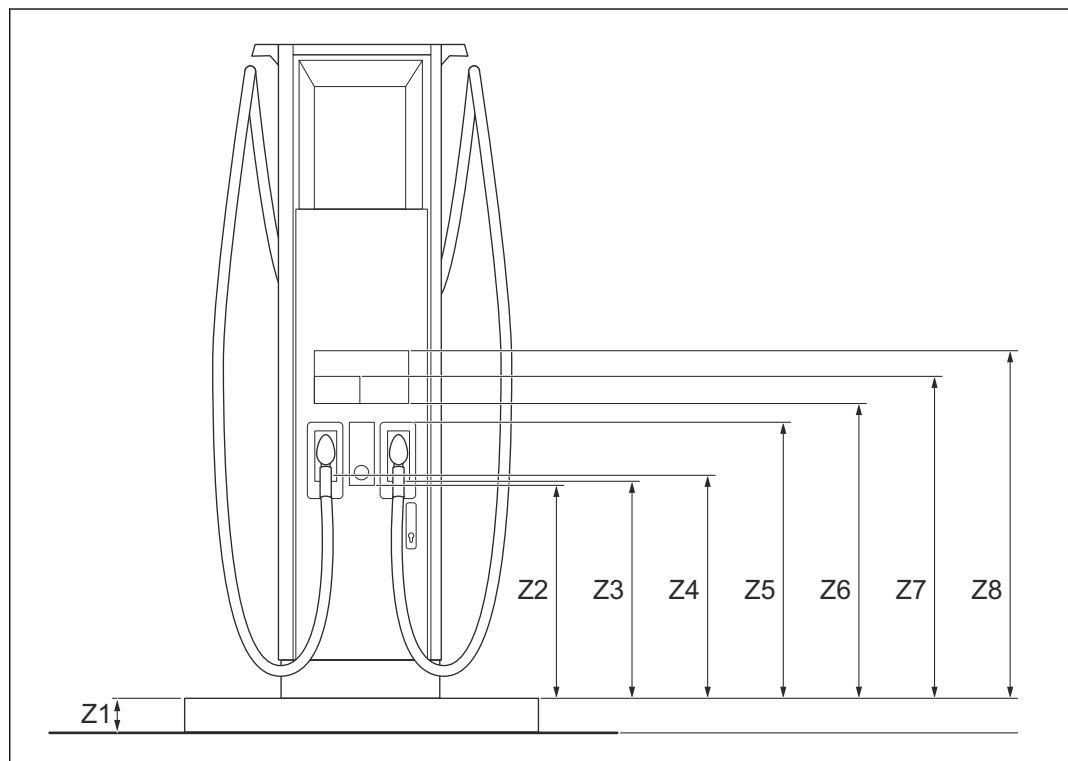

Parameter	Specification	Specification	
		[mm]	[in]
Z1	Advised maximum curb height	102	4
Z2	Bottom of the authentication cluster	750 or higher	29.5
Z3	CCS connector when holstered – center of grip	775	30.5
Z4	CHAdeMO connector when holstered – center of grip	790	31.1

Parameter		Specification	
		[mm]	[in]
Z5	Top of the authentication cluster	955	37.6
Z6	Bottom of the touch screen display	1026	40
Z7	Advised maximum height for user operable elements if the EVSE is placed on a curb. This requires HMI customization.	1118	44
Z8	Top of the touch screen display	1223	48.1

12.18 Space requirements

12.18.1 Power cabinet

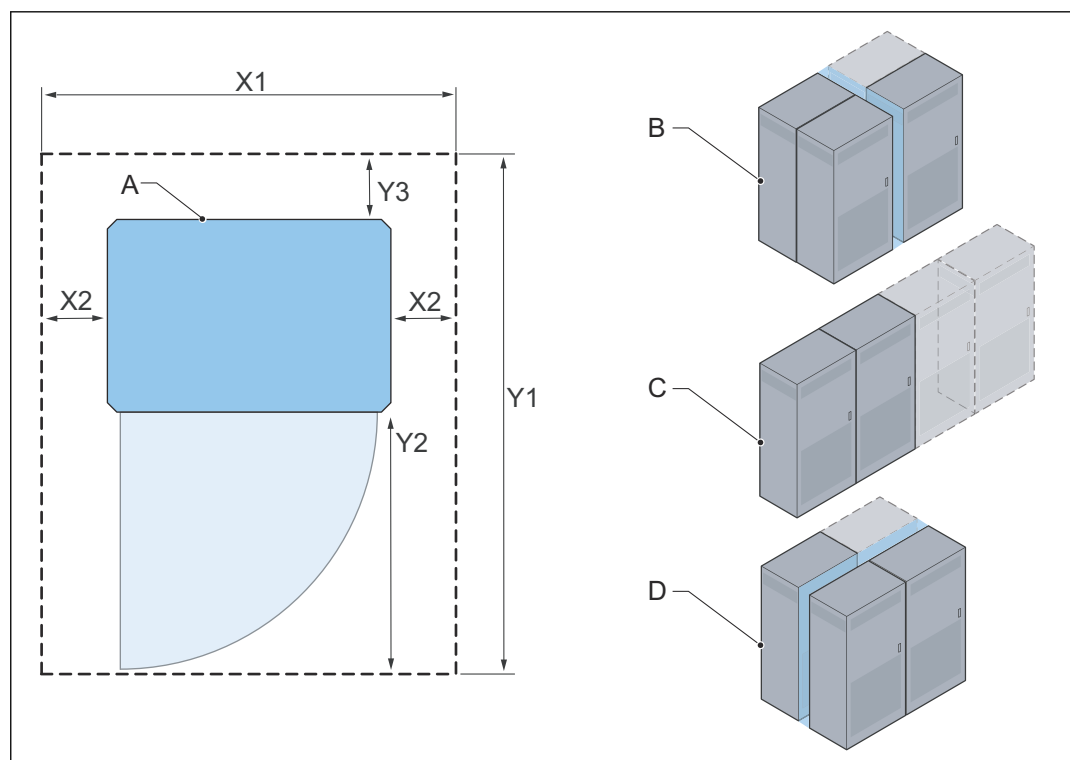

- | | | | |
|----|--|----|---|
| X1 | Total width required for the power cabinet | Y3 | Space for the rear air outlet |
| X2 | Space for the foundation | A | Power cabinet |
| X3 | Space to open the power cabinet door | B | Back to back configuration |
| Y1 | Total depth required for the power cabinet | C | Side by side configuration |
| Y2 | Space to open the power cabinet door | D | Side by side and back to back configuration |

Parameter	Specification for a single power cabinet	
	[mm]	[in]
X1	100 + 1170 + 100	3.9 + 46.1 + 3.9
X2	100	3.9
X3	650	25.6
Y1	1200 + 770 + 100	47.2 + 30.3 + 3.9
Y2	1200	47.2
Y3	100	3.9

Parameter	Specifications for configuration B	
	[mm]	[in]
X1	100 + 1170 + 100 + 1170 + 100	3.9 + 46.1 + 3.9 + 46.1 + 3.9
X2	100	3.9
X3	650	25.6
Y1	1200 + 770 + 770 + 1200	47.2 + 30.3 + 30.3 + 47.2
Y2	1200	47.2
Y3	0	0

Parameter	Specifications for configuration C	
	[mm]	[in]
X1	100 + 1170 + 100	3.9 + 46.1 + 3.9
X2	0 100 on the outer sides	0 3.9 on the outer sides
X3	650	25.6
Y1	1200 + 770 + 100	47.2 + 30.3 + 3.9
Y2	1200	47.2
Y3	100	3.9

Parameter	Specifications for configuration D	
	[mm]	[in]
X1	100 + 1170 + 1170 + 100	3.9 + 46.1 + 46.1 + 3.9
X2	0 100 on the outer sides	0 3.9 on the outer sides
X3	650	25.6
Y1	1200 + 770 + 770 + 100	47.2 + 30.3 + 30.3 + 3.9
Y2	1200	47.2
Y3	100	3.9

12.18.2 Charge post

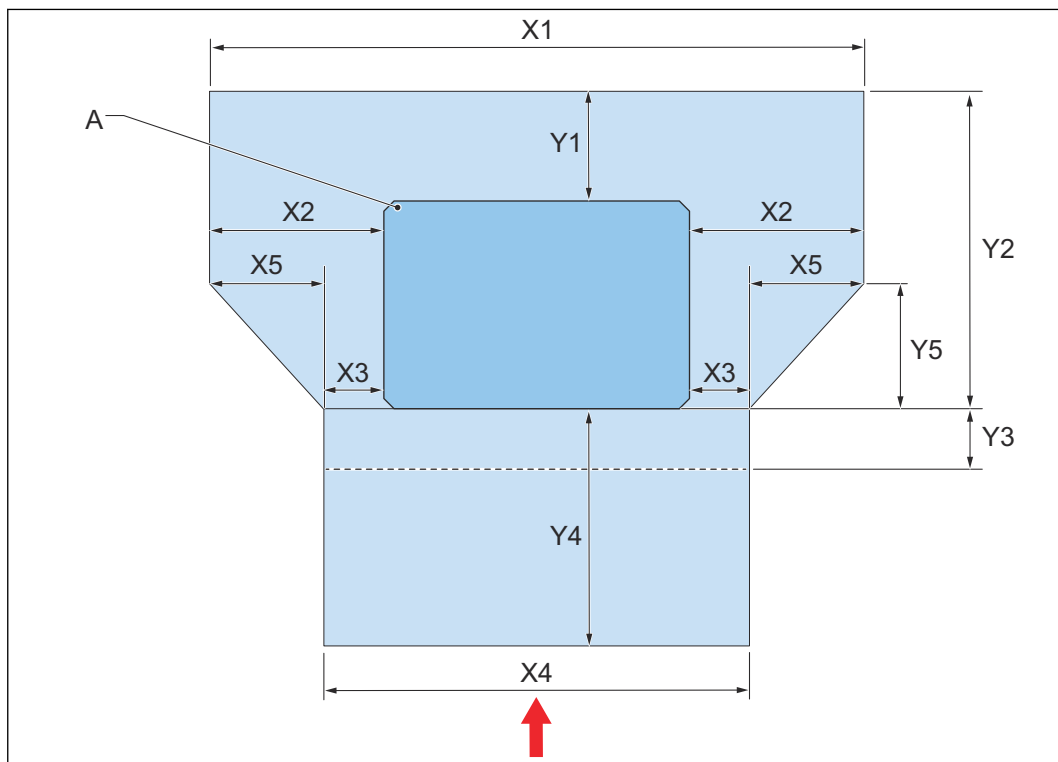

- A Charge post
- X1 Total required width for the charge post
- X2 Space required for the air inlet and to open the side panel
- X3 Space required at the sides to open the door
- X4 Total required width to open the door
- X5 Required width to open the side panel
- Y1 Space required for cable replacement
- Y2 Total required depth for the charge post
- Y3 Maximum sideways reach of the wheelchair user
- Y4 Space required to open the door
- Y5 Required depth to open the side panel

Parameter	Specification	
	[mm]	[in]
X1	1490	58.7
X2	450	17.7
X3	105	4.1
X4	800	31.5
X5	345	13.6
Y1	400	15.7
Y2	775	30.6
Y3	254	10
Y4	490	19.3
Y5	345	13.6

12.18.3

Charge post: exceptions for bollards and other minor fixed obstacles



Note:

The bollards or minor fixed obstacles must have a maximum diameter of 150 mm (6 in), to permit service or maintenance operations.

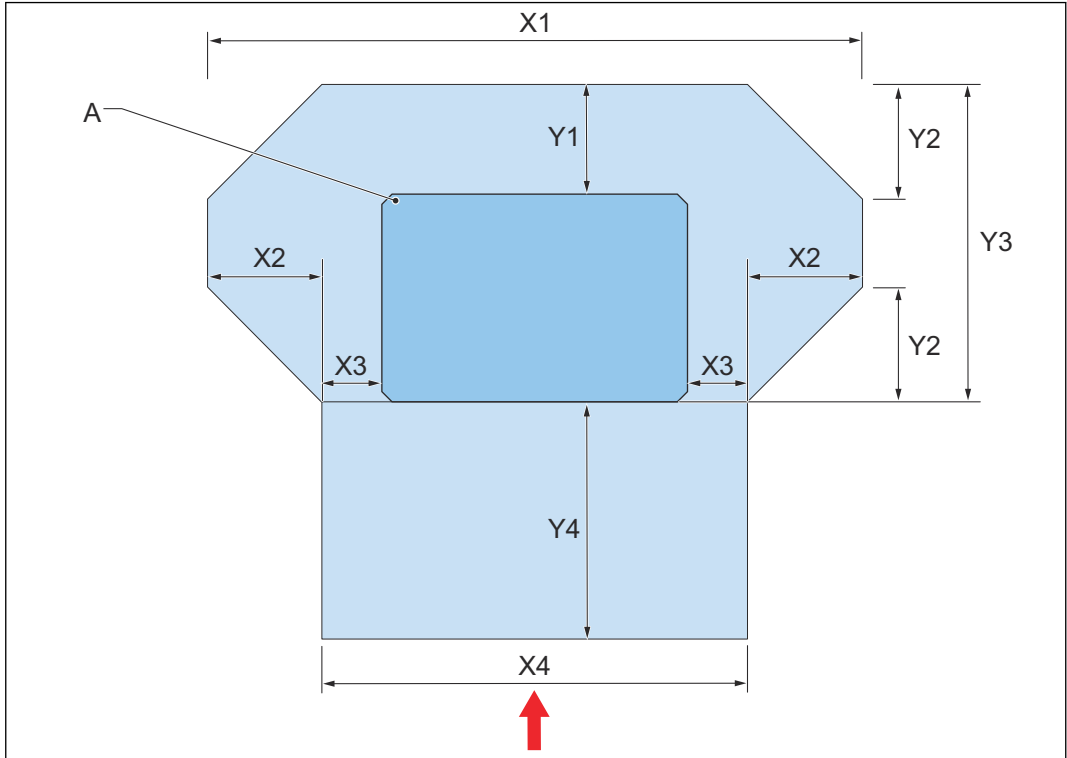

- | | | | |
|----|--|----|--|
| A | Charge post | Y1 | Required depth to open the side panel |
| X1 | Total width to open the side panels | Y2 | Required depth to open the side panel |
| X2 | Required width to open the side panel | Y3 | Total required width to open side panels |
| X3 | Space required at the sides to open the door | Y4 | Space required to open the door |
| X4 | Total required width to open the door | | |

Parameter	Specification	
	[mm]	[in]
X1	1190	46.8
X2	200	7.8
X3	105	4.1
X4	800	31.5
Y1	250	9.8
Y2	200	7.8
Y3	675	26.5
Y4	490	19.3

12.18.4 Distance requirements between power cabinet and charge post

Parameter	Specification	
	[m]	[ft]
Maximum distance between the power cabinet and the charge post	60	197

12.19 Foundation specifications

12.19.1 Power cabinet (prefab concrete)

General specifications

Parameter	Specification
Type	Base monoblock of support for cabinet, with plasticizer and waterproofing additive
Concrete class	C32 / 40
Exposure class	CX4 and XD25 according to UNI 11104:2018

Dimensions, side view

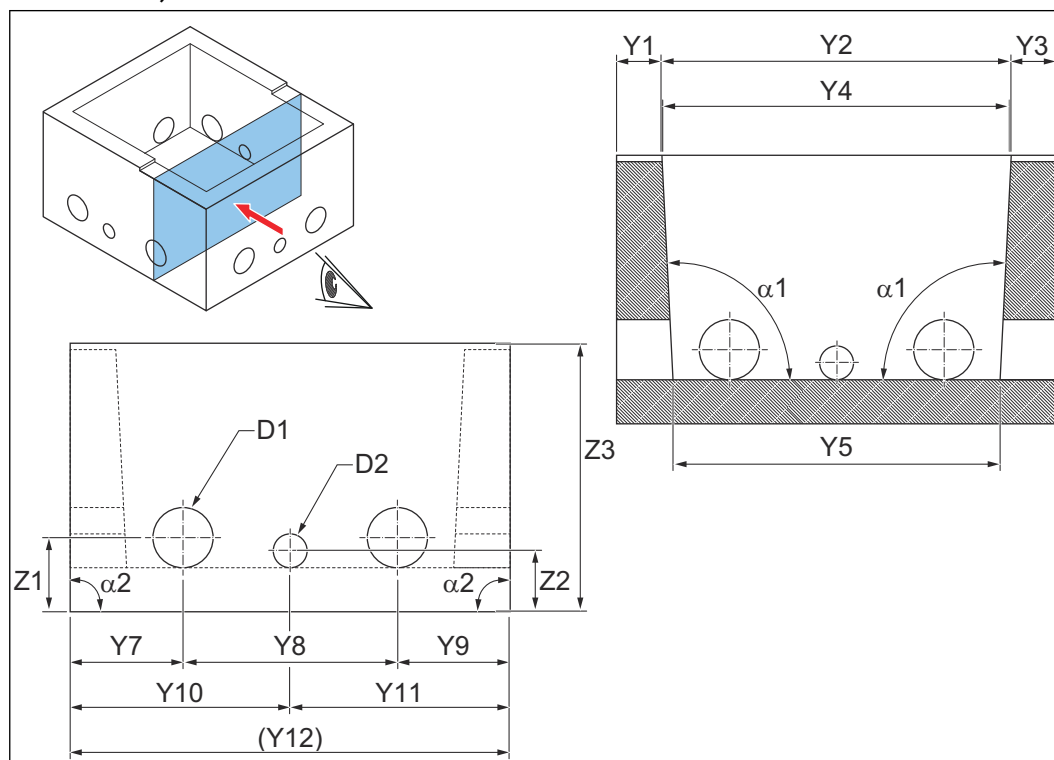

Parameter	Specification	
	[mm]	[in]
Y1	120	4.72
Y2	930	36.6

Technical data

Parameter	Specification	
	[mm]	[in]
Y3	120	4.72
Y4	928	36.5
Y5	870	34.3
Y6	1170	46.1
Y7	300	11.8
Y8	570	22.4
Y9	300	11.8
Y10	585	23.0
Y11	585	23.0
(Y12)	1170	46.1
Z1	200	7.87
Z2	185	7.28
Z3	720	28.3
D1 (8x), diameter	160	6.30
D1 (4x), diameter	90	3.54

Parameter	Specification
$\alpha 1$	93°
$\alpha 2$	90°
D1 hole	3° tapered
D2 hole	3° tapered

Dimensions, front view

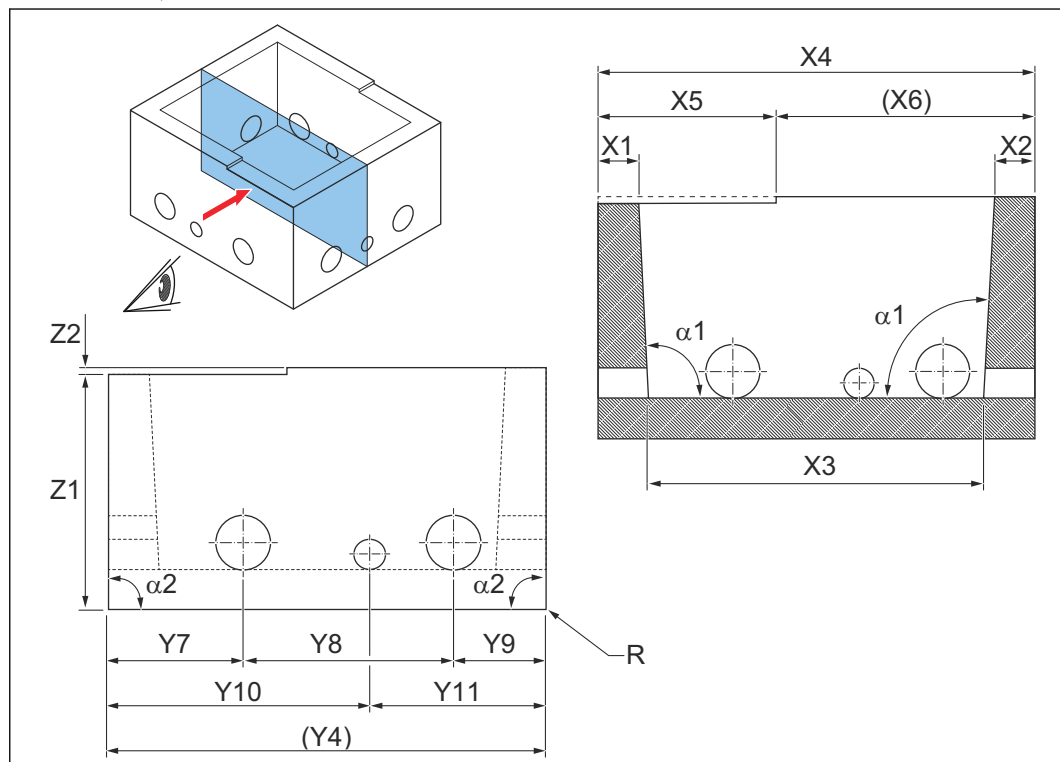

Parameter	Specification	
	[mm]	[in]
X1	120	4.72
X2	120	4.72
X3	1000	39.4
X4	1300	51.2
X5	530	20.9
(X6)	770	30.3
X7	400	15.7
X8	625	24.6
X9	275	10.8
X10	775	30.5
X11	525	20.7
(X12)	1300	51.2
Z1	700	27.6
Z2	20	0.79
R, all edges	3	0.1

Parameter	Specification
alpha1	93°
alpha2	90°

Dimensions, top view

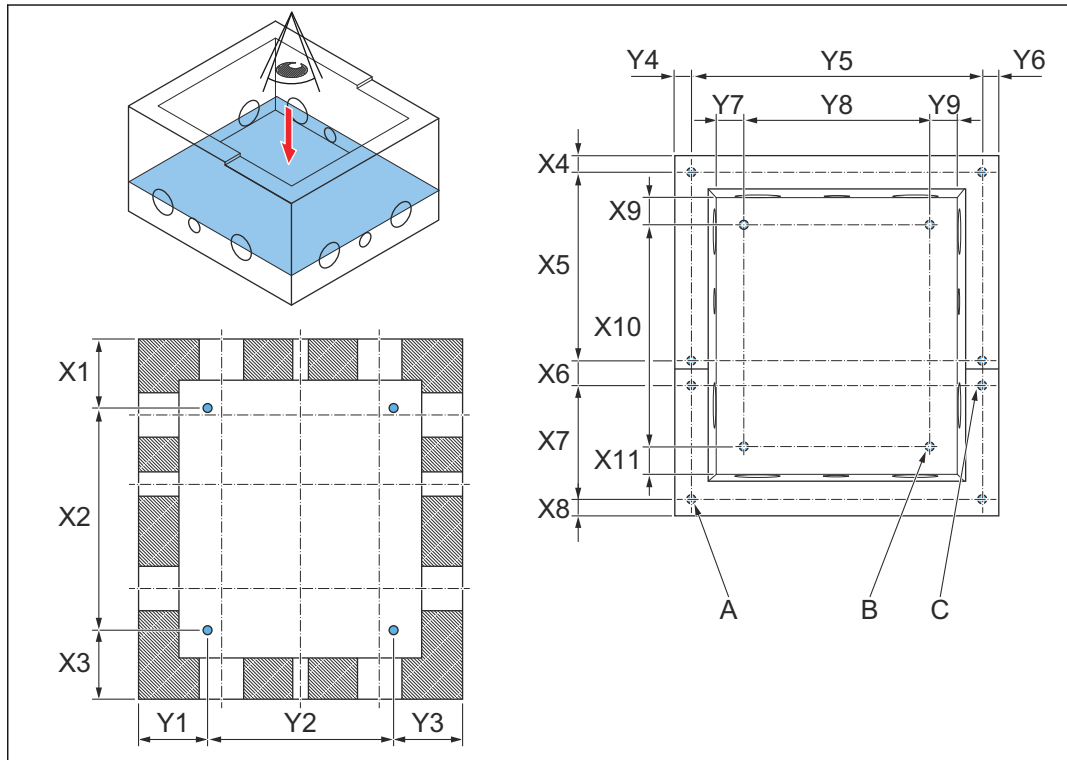

Parameter	Specification	
	[mm]	[in]
X1	250	9.84
X2	800	31.5
X3	250	9.84
X4	60	2.3
X5	680 +/- 1	26.8 +/- 0.1
X6	90	3.5
X7	410 +/- 1	16.1 +/- 0.1
X8	60	2.3
X9	100	3.94
X10	800 +/- 1	31.5 +/- 0.1
X11	100	3.94
X12	100	3.94
Y1	250	9.84
Y2	670	26.4
Y3	250	9.84
Y4	60	2.3
Y5	1050 +/- 1	41.3 +/- 0.1
Y6	60	2.3
Y7	100	3.94
Y8	670 +/- 1	26.4 +/- 0.1

Parameter	Specification	
	[mm]	[in]
Y9	100	3.94
Y10	100	3.94

Parameter	Specification
A (4x)	T-Fixx M16 depth 80 (3.1) RVS
B (4x)	T-Fixx M10 depth 65 (2.6) RVS
C (4x)	T-Fixx M10 depth 65 (2.6) RVS

12.19.2 Power cabinet (custom)

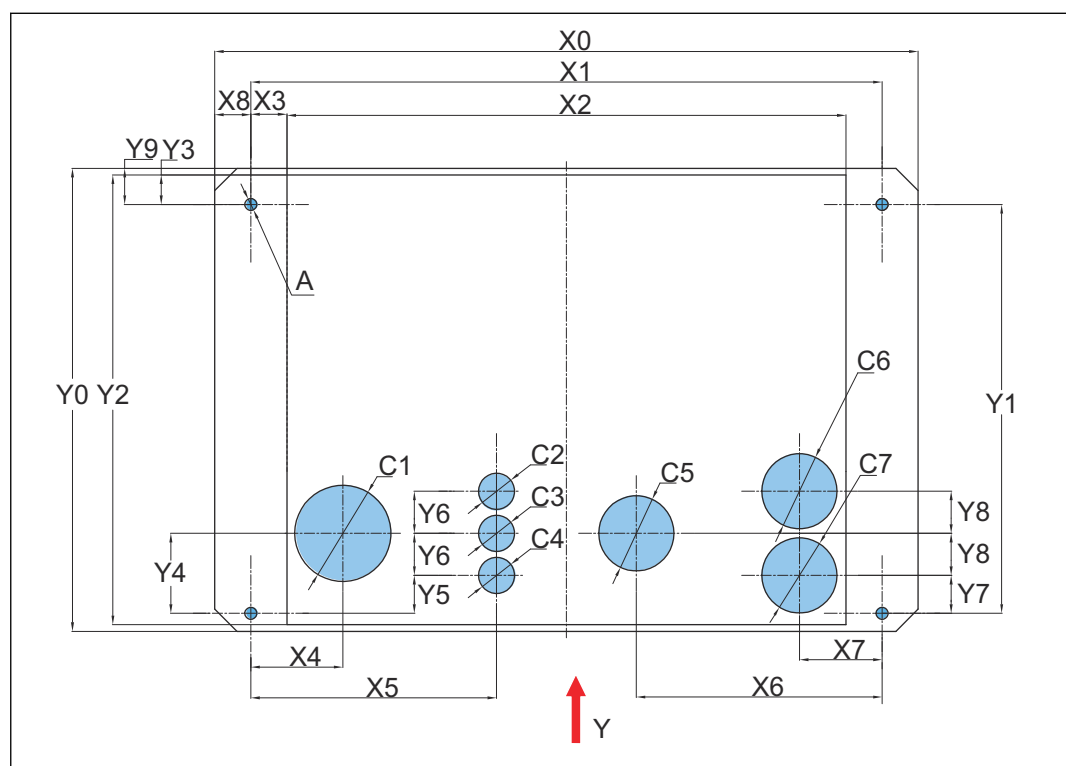

Note: The arrow shows the front side of the power cabinet.

Parameter	Specification	
A (4x)	For M16 fasteners, depth 60 (2.4)	

Parameter	Specification	
	[mm]	[in]
X0	1170	46.1
X1	1050	41.3
X2	930	36.6
X3	60	2.4

Parameter	Specification	
	[mm]	[in]
X4	153	6.0
X5	409	16.1
X6	409	16.1
X7	138	5.4
X8	60	2.4
Y0	770	30.3
Y1	680	26.8
Y2	748	29.4
Y3	49	1.9
Y4	133	5.2
Y5	63	2.5
Y6	70	2.8
Y7	63	2.5
Y8	70	2.8

Cable conduit hole	Maximum diameter	
	[mm]	[in]
C1	160	6.3
C2	60	2.4
C3	60	2.4
C4	60	2.4
C5	125	4.9
C6	125	4.9
C7	125	4.9

Function for cable conduit holes

Cable conduit hole	Cable conduit for these cables
C1	AC power
C2	None
C3	CAN, interlock and DC guard: to the charge post
C4	AC auxiliary and PE: to the charge post
C5	None
C6	None
C7	DC power: to the charge post

12.19.3 Charge post (prefab concrete)

Foundation mass and loads

Parameter	Specification
Mass	950 kg (2094 lb)
Nd	15.06 kN (3386 klbf)
Vd	5.25 kN (1180 klbf)
Md	8.36 kNm (74.1 klb-in)

Dimensions, side views

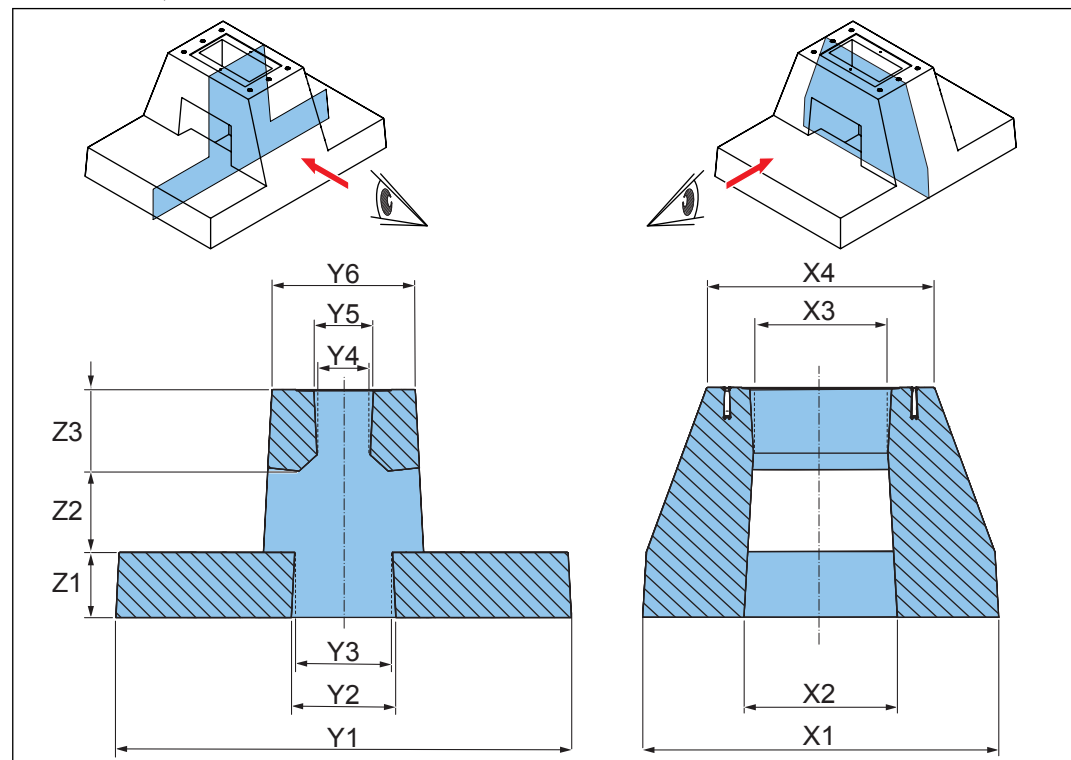

Parameter	Specification	
	[mm]	[in]
X1	1000	39.37
X2	431	16.97
X3	379	14.92
X4	640	25.20
Y1	1400	55.12
Y2	321	12.64
Y3	274	10.79
Y4	163	6.42
Y5	184	7.24
Y6	440	17.32
Z1	200	7.87

Parameter	Specification	
	[mm]	[in]
Z2	250	9.84
Z3	250	9.84

Dimensions, top view

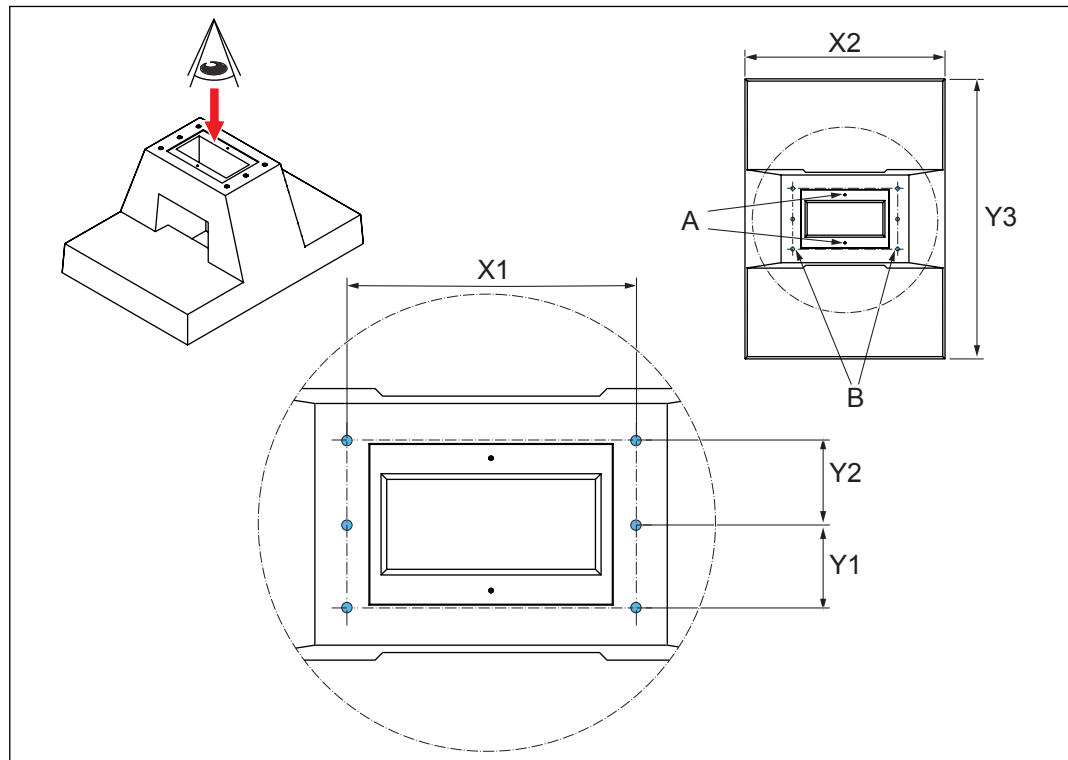

Parameter	Specification	
	[mm]	[in]
X1	526	20.71
X2	1000	39.37
Y1	150	5.91
Y2	150	5.91
Y3	1400	55.12

Parameter	Specification
A (2x)	DEMU anchor type 1988 type M16 depth 20 (8.66)
B (6x)	DEMU T-FIXX A4 anchor type M12 depth 115 (4.53)

12.19.4 Charge post (custom)

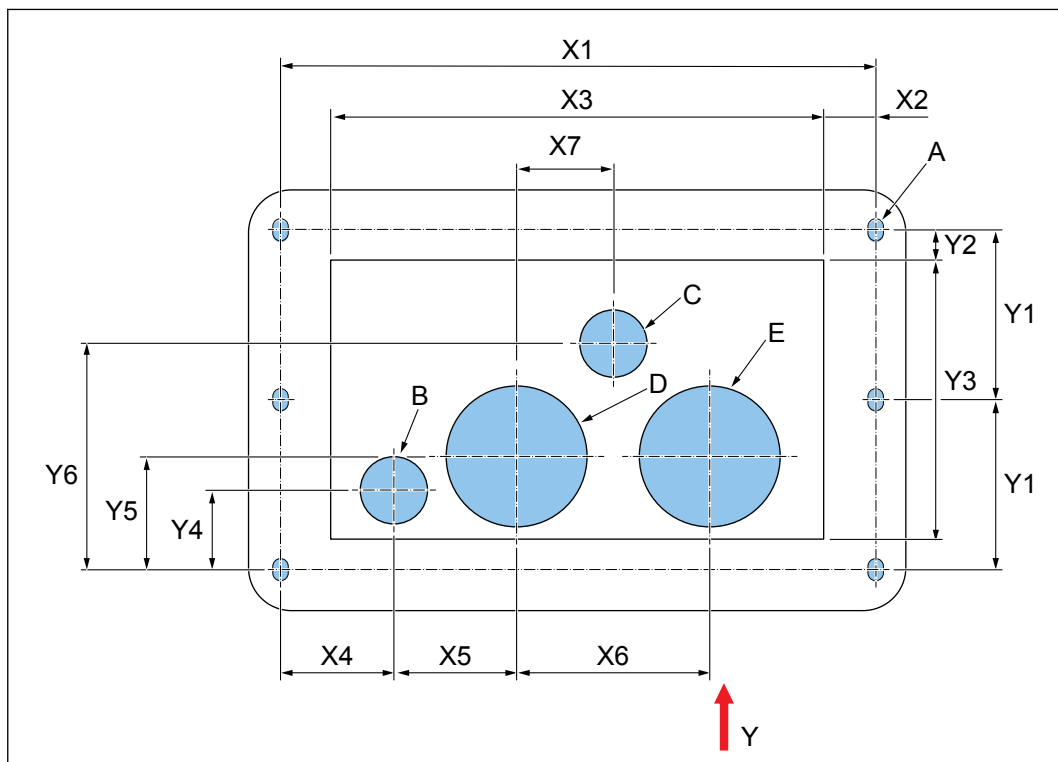

Note: The arrow shows the front side of the charge post.

Parameter	Specification	
	[mm]	[in]
X0	580	22.8
X1	526	20.7
X2	45	1.8
X3	436	17
X4	100	3.9
X5	110	4.3
X6	170	6.7
X7	85	3.3
Y0	371	14.6
Y1	150	5.9
Y2	26	1.0
Y3	248	9.8
Y4	70	2.8
Y5	100	3.9
Y6	200	7.9

Parameter	Specification	
A (6x)	For M12 fasteners diameter 14 (0.6)	

Cable conduit hole	Function for cable conduit holes	Maximum diameter	
		[mm]	[in]
B	AC auxiliary and PE	60	2.4
C	CAN, Interlock, and DC guard	60	2.4
D	DC- power	126	5.0
E	DC+ power	126	5.0

Function for cable conduit holes

Cable conduit hole	Cable conduit for these cables
C1	AC auxiliary and PE
C2	CAN, interlock and DC guard
C3	DC power
C4	DC power

12.20

Overview of the cable conduits



Note: For a detailed overview of all electrical connections, refer to section 12.23.

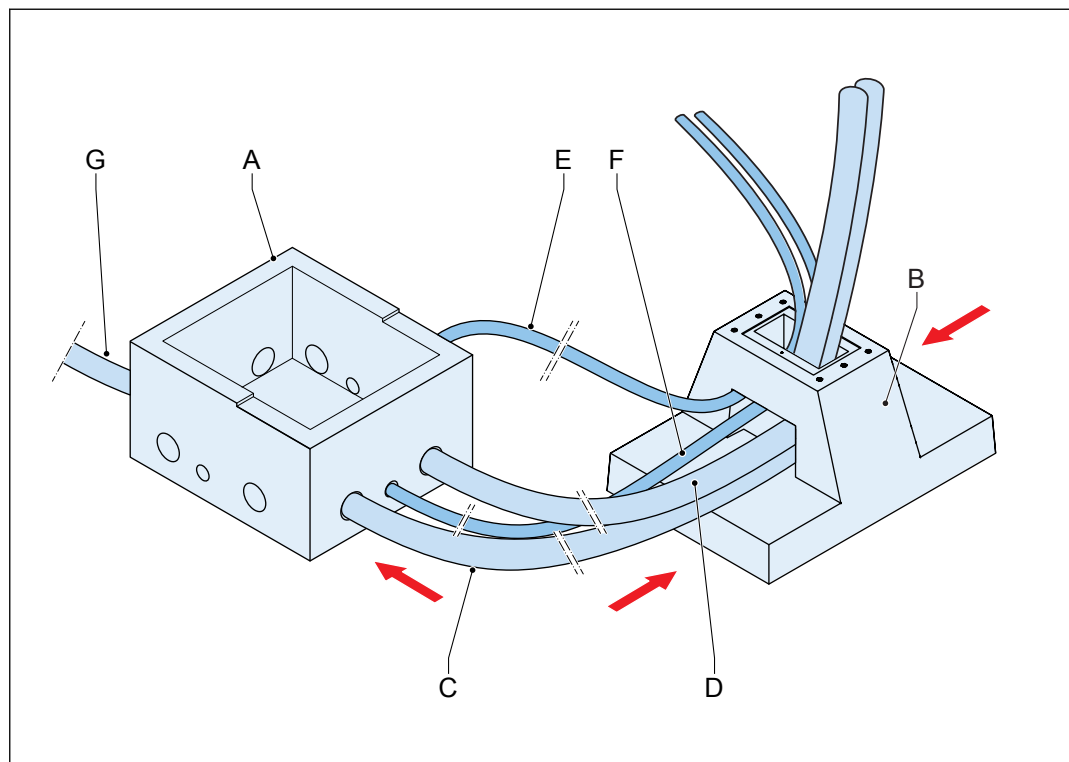

A Foundation of the power cabinet

B Foundation of the charge post



Note: The arrows show the front side of the charge post and the power cabinet.

Cable conduit	Cables
C	DC- power
D	DC+ power
E	Ethernet Interlock DC guard
F	AC auxiliary PE
G	AC power

Maximum diameter of the cable conduit of the power cabinet	Specification	
	[mm]	[in]
Small holes	90	3.54
Large holes	160	6.3

12.21 Cable specifications

12.21.1 AC input cable for the power cabinet

Parameter	Specification
Cores	3 wires + PE, according to IEC 60446
Cross section range	185 mm ² to 240 mm ² (365 kcmil to 474 kcmil)
Conductor	Bare copper, fine wired, bunch stranded, according to VDE 0295 Cl.5/IEC Cl.5
Diameter of the phase conductors	Refer to the local rules.
Insulation	PVC that is serviceable for outdoor use, UV-protected, and oil resistant
Minimum nominal voltage U ₀ /U	450/750 VAC
Minimum test voltage	4 kV
Ambient temperature range	-40 °C to +80 °C (-40 °F to +176 °F)
Diameter of the PE conductor	The same as the diameter of the phase conductors

12.21.2 DC power installation cables

The below data are specific for the DC power cables between the power cabinet and the charge post.

Parameter	Specification
Type	1x Positive, 1x negative cable Flexible Unshielded
Number of cores	1
Cross section range (minimum)	185 mm ² (365 kcmil)
Cross section range (maximum)	300 mm ² (592 kcmil)
Diameter	27 to 35 mm (1.1 to 1.4 in)
Maximum length	60 m (197 ft)
Conductor	Fine wire, stranded in tin plated copper or aluminum, according to VDE 0295 cl.5/IEC Cl.5
Diameter of the phase conductors	Refer to the local rules.
Insulation	Rubber or PVC that is serviceable for outdoor use, UV-protected, and oil resistant
Nominal voltage U _o (Phase to ground nominal voltage) /U (Phase to phase nominal voltage)	600/1000 Vac - 900/1500 Vdc
Minimum test voltage	6 kV
Ambient temperature range	-40°C to 80°C (-40 °F to 176 °F)
Maximum cable temperature (on the surface)	+90°C (+194 °F)

12.21.3

PE cable

Parameter	Specification
Cores	1 core, gn/ye
Cross section range	35 mm ² (69 kcmil) (2 AWG)
Type	Flexible, unshielded
Diameter	13 - 21 mm
Length	Refer to the local rules.
Conductor	Fine strand copper wire according to VDE 0295 Cl. 5/ IEC 60228 Cl. 5
Insulation	Special PVC that is serviceable for outdoor use, UV-protected, and oil resistant
Minimum nominal voltage U _o /U	600/1000 Vac
Minimum test voltage	4 kV
Ambient temperature range	-40°C to 80°C (-40 °F to +176 °F)
Diameter of the PE conductor	The same as the diameter of the phase conductors

12.21.4 AC auxiliary power cables

Parameter	Specification
Number of cores	4
Cross section range	2.5 mm ² (14 AWG)
Shielding	No
Conductor	Bare copper, fine wired, brunch stranded according to VDE 0295 Cl.5/IEC Cl.5
Insulation	Special PVC (that is serviceable for outdoor use, UV-protected, and oil resistant
Minimum nominal voltage (U _o /U)	450/750 Vac
Minimum test voltage (AC)	4 kV
Ambient temperature range	-40°C to +80°C (-40 °F to +176 °F)
Core identification	According to IEC 60446
Strip length	11 mm (0.43 in)

12.21.5 Interlock and DC guard cables

Parameter	Specification
Number of cores	2 x 2 twisted pair (4 core)
Diameter (inside)	1.3 to 2.1 mm ² (16 to 14 AWG)
Diameter (outside)	10 to 17 mm (0.39 to 0.67 in)
Shielding	Tinned copper braid Possible configuration: shielded 4 core cable 2 x 2 pairs twisted or two separate shielded dual core cables
Conductor	Fine strand copper wire
Insulation	PVC or other material that is serviceable for outdoor use and UV-protected
Test voltage	1.5 kV
Strip length	11 mm (0.43 in)

12.21.6 Optical CAN cables between the power cabinet and the charge post

Parameter	Specification
Number of cores	2 fibre cores for installation 2 fibre cores as spare parts
Type	OM3 (multimode) prefabricated
Connector	B-FOC (ST®)
Diameter	13 to 21 mm (0.51 to 0.83 in)
Wave length	850 nm
Material	PCF or fiberglass
Loop bend radius	Minimum 64 mm (2.5 in)
Strip length	11 mm (0.43 in)

12.21.7 Cable for the tilt sensor control



Note: The tilt sensor control cables must be suitable for a 600 V environment.

Parameter	Specification
Number of cores	2 x 2 twisted pair (4 core)
Diameter (inside)	0.75 to 2.5 mm ² (1.5 to 4.9 kcmil)
Diameter (outside)	5 to 10 mm (0.20 to 0.39 in)
Conductor	Fine strand copper wire
Insulation	PVC or other material that is serviceable for outdoor use and UV-protected
Minimum test	1.5 kV
Strip length	11 mm (0.43 in)

12.21.8 Ethernet cable

Parameter	Specification
Type	Shielded (tinned copper braid)
Number of (twisted) pairs	4 x 2
Core identification	Acc. to DIN 47100
Cross section	0.5 - 0.75 mm ²
Diameter	5 - 10mm
Conductor	Fine strand copper wire
Insulation	PVC that is serviceable for outdoor use, UV-protected, and oil resistant
Characteristic impedance	120 Ω ± 10%
Voltage rating	600 VAC
Test voltage	1.5 kV
Ambient temperature range	-40°C to 80°C

12.22 AC input connection configuration

The charge post can be connected to one of the following three-phase systems:

- TN-C
- TN-C-S
- TN-S
- TT

TN-C

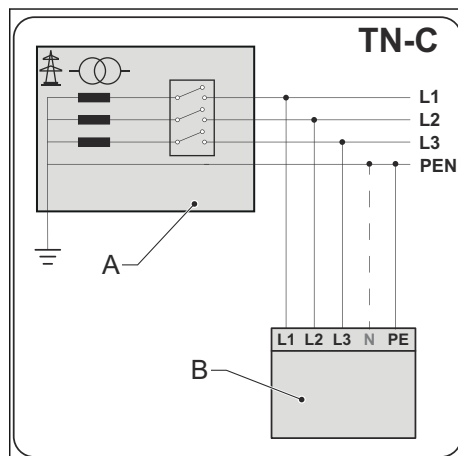

A Power distribution board

B Power cabinet

- Wire L1, L2, L3
- Wire N (if available on the EVSE)
- Wire PEN to the EVSE grounding bar without interruption
- Avoid the use of an RCD. If a dedicated three-phase line is available for the EVSE, an RCD can be used.

TN-C-S

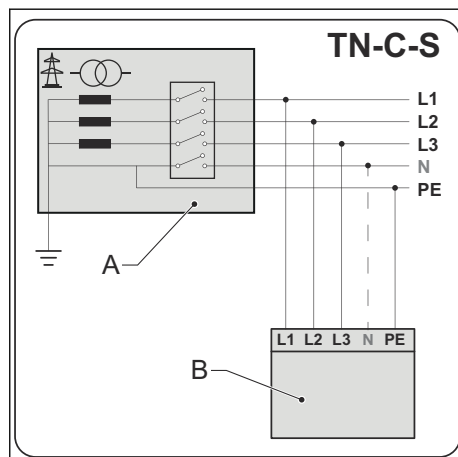

A Power distribution board

B Power cabinet

- Wire L1, L2, L3
- Wire N (if available on the EVSE)
- Wire PE to the EVSE grounding bar without interruption
- An adjustable RCD is recommended

TN-S

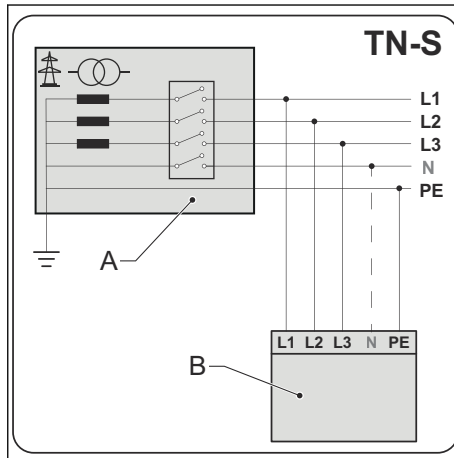

A Power distribution board

B Power cabinet

- Wire L1, L2, L3
- Wire N (if available on the EVSE)
- Wire PE to the EVSE grounding bar without interruption
- An adjustable RCD is recommended.

TT

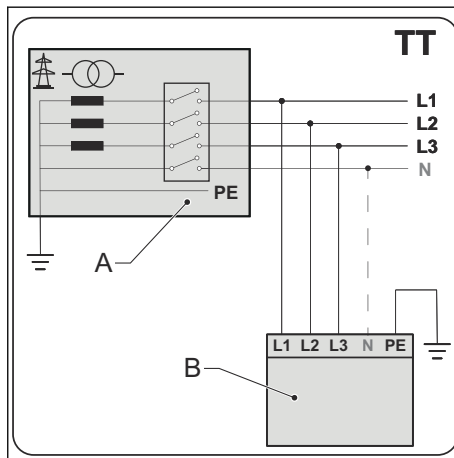

A Power distribution board

B Power cabinet

- Wire L1, L2, L3
- Wire N (if available on the EVSE)
- Do not wire Main PE to the EVSE
- Connect Local PE to the EVSE grounding bar
- An adjustable RCD is mandatory.

12.23 Electrical connection diagram

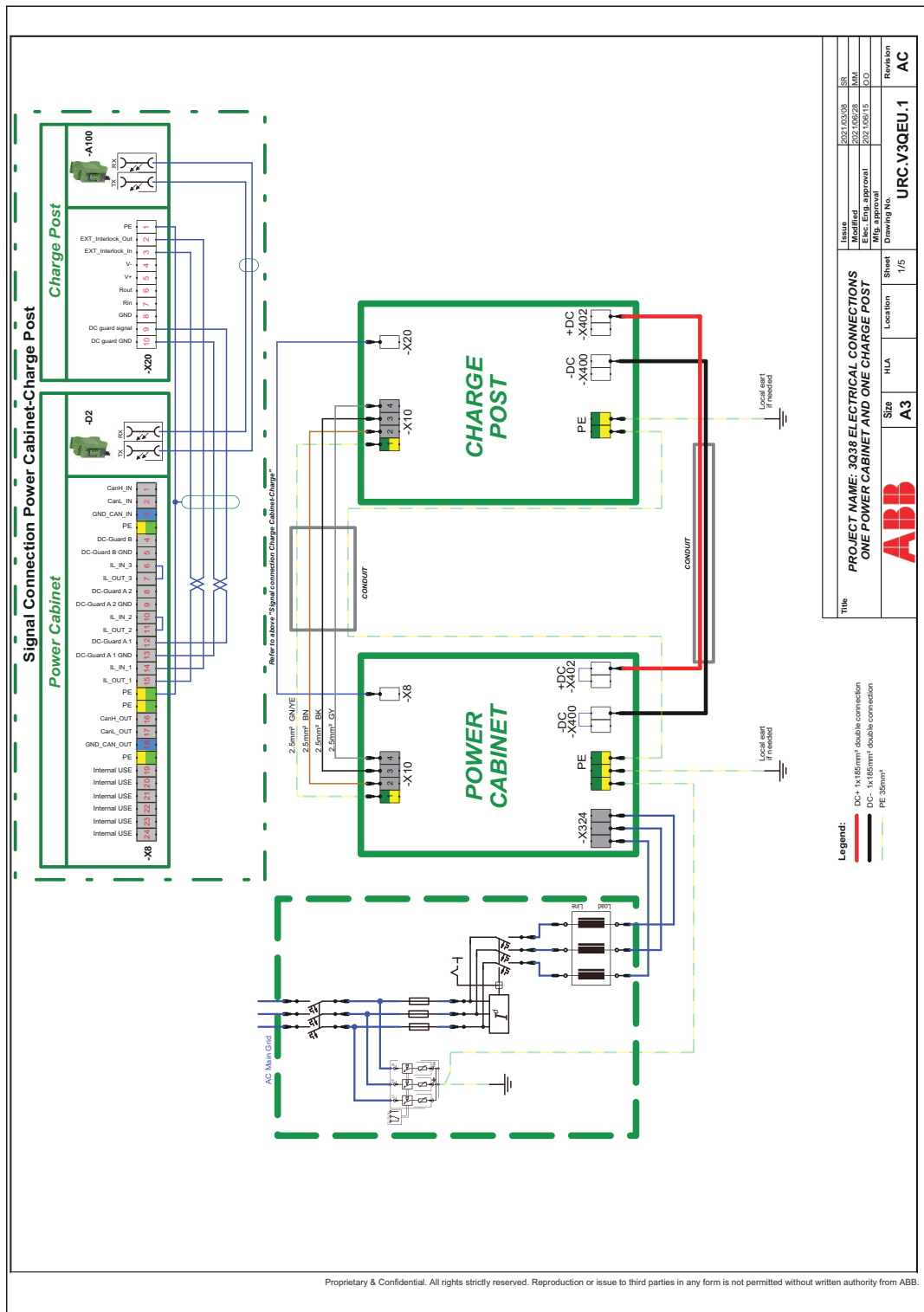

Proprietary & Confidential. All rights strictly reserved. Reproduction or issue to third parties in any form is not permitted without written authority from ABB.

13 Appendix

13.1 Messrichtigkeitshinweise gemäß Baumusterprüfbescheinigung

I Auflagen für den Betreiber der Ladeeinrichtung, die dieser als notwendige Voraussetzung für einen bestimmungsgemäßen Betrieb der Ladeeinrichtung erfüllen muss.

Der Betreiber der Ladeeinrichtung ist im Sinne § 31 des Mess- und Eichgesetzes der Verwender des Messgerätes.

1. Die Ladeeinrichtung gilt nur dann als eichrechtlich bestimmungsgemäß und eichrechtkonform verwendet, wenn sie nicht anderen Umgebungsbedingungen ausgesetzt ist als denen, für die ihre Baumusterprüfbescheinigung erteilt wurde. Diese sind in den technischen Begleitunterlagen der Ladeeinrichtung beschrieben.
2. Der Verwender dieses Produktes muss bei Anmeldung der Ladepunkte bei der Bundesnetzagentur in deren Anmeldeformular den an der Ladeeinrichtung zu den Ladepunkten angegebenen PK mit anmelden! Ohne diese Anmeldung ist ein eichrechtkonformer Betrieb der Ladeeinrichtung nicht möglich. Weblink: <https://www.bundesnetzagentur.de/DE/Fachthemen/ElektrizitaetundGas/E-Mobilitaet/Ladesaeulenkarte/Karte/start.html>
3. Der Verwender dieses Produktes hat sicherzustellen, dass die Eichgültigkeitsdauern für die Komponenten in der Ladeeinrichtung und für die Ladeeinrichtung selbst nicht überschritten werden.
4. Der Verwender dieses Produktes hat sicherzustellen, dass Ladeeinrichtungen zeitnah außer Betrieb genommen werden, wenn wegen Stör- oder Fehleranzeigen im Display der eichrechtlich relevanten Mensch-Maschine-Schnittstelle ein eichrechtkonformer Betrieb nicht mehr möglich ist. Es ist der Katalog der Stör- und Fehlermeldungen in dieser Betriebsanleitung zu beachten.
5. Der Verwender muss die aus der Ladeeinrichtung ausgelesenen, signierten Datenpakete - entsprechend der Paginierung lückenlos dauerhaft (auch) auf diesem Zweck gewidmeter Hardware in seinem Besitz speichern („dedizierter Speicher“), - für berechtigte Dritte verfügbar halten (Betriebspflicht des Speichers.). Weiterhin muss der Verwender aus Ladeeinrichtungen ausgebaute Zusatzmodule dauerhaft aufbewahren und ein Auslesen der gespeicherten eichtechnischen Logbücher ermöglichen, wenn eine berechtigte Behörde dies verlangt. Dauerhaft bedeutet, dass die Daten nicht nur bis zum Abschluss des Geschäftsvorganges gespeichert werden müssen, sondern mindestens bis zum Ablauf möglicher gesetzlicher Rechtsmittelfristen für den Geschäftsvorgang. Für nicht vorhandene Daten dürfen für Abrechnungszwecke keine Ersatzwerte gebildet werden.
6. Der Verwender dieses Produktes hat Messwertverwendern, die Messwerte aus diesem Produkt von ihm erhalten und im geschäftlichen Verkehr verwenden, eine elektronische Form einer von der Konformitätsbewertungsstelle genehmigten Betriebsanleitung zur Verfügung zu stellen. Dabei hat der Verwender dieses Produktes insbesondere auf die Nr. II „Auflagen für den Verwender der Messwerte aus der Ladeeinrichtung“ hinzuweisen.
7. Den Verwender dieses Produktes trifft die Anzeigepflicht gemäß § 32 MessEG (Auszug):
§ 32 Anzeigepflicht (1) Wer neue oder erneuerte Messgeräte verwendet, hat diese der nach Landesrecht zuständigen Behörde spätestens sechs Wochen nach Inbetriebnahme anzuzeigen...
8. Soweit es von berechtigten Behörden als erforderlich angesehen wird, muss vom Messgeräteverwender der vollständige Inhalt des dedizierten lokalen oder des Speichers beim CPO mit allen Datenpaketen des Abrechnungszeitraumes zur Verfügung gestellt werden.

II Auflagen für den Verwender der Messwerte aus der Ladeeinrichtung (EMSP)

Der Verwender der Messwerte hat den § 33 des MessEG zu beachten:

§ 33 MessEG (Zitat)

§ 33 Anforderungen an das Verwenden von Messwerten

(1) Werte für Messgrößen dürfen im geschäftlichen oder amtlichen Verkehr oder bei Messungen im öffentlichen Interesse nur dann angegeben oder verwendet werden, wenn zu ihrer Bestimmung ein Messgerät bestimmungsgemäß verwendet wurde und die Werte auf das jeweilige Messergebnis zurückzuführen sind, soweit in der Rechtsverordnung nach § 41 Nummer 2 nichts anderes bestimmt ist. Andere bundesrechtliche Regelungen, die vergleichbaren Schutzzwecken dienen, sind weiterhin anzuwenden.

(2) Wer Messwerte verwendet, hat sich im Rahmen seiner Möglichkeiten zu vergewissern, dass das Messgerät die gesetzlichen Anforderungen erfüllt und hat sich von der Person, die das Messgerät verwendet, bestätigen zu lassen, dass sie ihre Verpflichtungen erfüllt.

(3) Wer Messwerte verwendet, hat

1. dafür zu sorgen, dass Rechnungen, soweit sie auf Messwerten beruhen, von demjenigen, für den die Rechnungen bestimmt sind, in einfacher Weise zur Überprüfung angegebener Messwerte nachvollzogen werden können und
2. für die in Nummer 1 genannten Zwecke erforderlichenfalls geeignete Hilfsmittel bereitzustellen.

Für den Verwender der Messwerte entstehen aus dieser Regelung konkret folgende Pflichten einer eichrechtkonformen Messwertverwendung:

1. Der Vertrag zwischen EMSP und Kunden muss unmissverständlich regeln, dass ausschließlich die Lieferung elektrischer Energie und nicht die Ladeservice-Dauer Gegenstand des Vertrages ist.
2. Die Zeitstempel an den Messwerten stammen von einer Uhr in der Ladeeinrichtung, die nicht nach dem Mess- und Eichrecht zertifiziert ist. Sie dürfen deshalb nicht für eine Tarifierung der Messwerte verwendet werden.
3. EMSP muss sicherstellen, dass der Vertrieb der Elektromobilitätsdienstleistung mittels Ladeeinrichtungen erfolgt, die eine Beobachtung des laufenden Ladevorgangs ermöglichen, sofern es keine entsprechende lokale Anzeige an der Ladeeinrichtung gibt. Zumindest zu Beginn und Ende einer Ladesession müssen die Messwerte dem Kunden eichrechtlich vertrauenswürdig zur Verfügung stehen.
4. Der EMSP muss dem Kunden die abrechnungsrelevanten Datenpakete zum Zeitpunkt der Rechnungsstellung einschließlich Signatur als Datenfile in einer Weise zur Verfügung stellen, dass sie mittels der Transparenz- und Displaysoftware auf Unverfälschtheit geprüft werden können. Die Zurverfügungstellung kann über eichrechtlich nicht geprüfte Kanäle erfolgen.
5. Der EMSP muss dem Kunden die zur Ladeeinrichtung gehörige Transparenz- und Displaysoftware zur Prüfung der Datenpakete auf Unverfälschtheit verfügbar machen.
6. Der EMSP muss beweissicher prüfbar zeigen können, welches Identifizierungsmittel genutzt wurde, um den zu einem bestimmten Messwert gehörenden Ladevorgang zu initiieren. Das heißt, er muss für jeden Geschäftsvorgang und in Rechnung gestellten Messwert beweisen können, dass er diesen die Personenidentifizierungsdaten zutreffend zugeordnet hat. Der EMSP hat seine Kunden über diese Pflicht in angemessener Form zu informieren.
7. Der EMSP darf nur Werte für Abrechnungszwecke verwenden, die in einem ggf. vorhandenen dedizierten Speicher in der Ladeeinrichtung und oder dem Speicher beim Betreiber der Ladeeinrichtung vorhanden sind. Ersatzwerte dürfen für Abrechnungszwecke nicht gebildet werden.
8. Der EMSP muss durch entsprechende Vereinbarungen mit dem Betreiber der Ladeeinrichtung sicherstellen, dass bei diesem die für Abrechnungszwecke genutzten Datenpakete ausreichend lange gespeichert werden, um die zugehörigen Geschäftsvorgänge vollständig abschließen zu können.
9. Der EMSP hat bei begründeter Bedarfsmeldung zum Zwecke der Durchführung von Eichungen, Befundprüfungen und Verwendungsüberwachungsmaßnahmen durch Bereitstellung geeigneter Identifizierungsmittel die Authentifizierung an den von ihm genutzten Exemplaren des zu dieser Betriebsanleitung gehörenden Produktes zu ermöglichen.
10. Alle vorgenannten Pflichten gelten für den EMSP als Messwerteverwender im Sinne von § 33 MessEG auch dann, wenn er die Messwerte aus den Ladeeinrichtungen über einen Roaming-Dienstleister bezieht.
11. Der EMSP hat dafür zu sorgen, dass dem Kunden alle notwendigen Informationen zugestellt werden, die er für den Erhalt seines dauerhaften Nachweises benötigt. Im Fall des punktuellen Ladens sind daher die Internetseite des Belegservers sowie der Rechnungsbetrag und das Datum des Ladevorgangs auf der Kreditkartenrechnung oder dem Verwendungszweck der Kontobelastung anzugeben. Fehlen diese notwendigen Angaben handelt es sich um eine nicht bestimmungsgemäße Verwendung des Messgerätes.
12. Bei der Nutzung des punktuellen Ladens hat der EMSP den Kunden beim Erhalt des dauerhaften Nachweises eindeutig darauf hinzuweisen, wie der im Datentupel hinterlegte Preis pro Einheit dem Kunden in Klartext angezeigt werden kann.

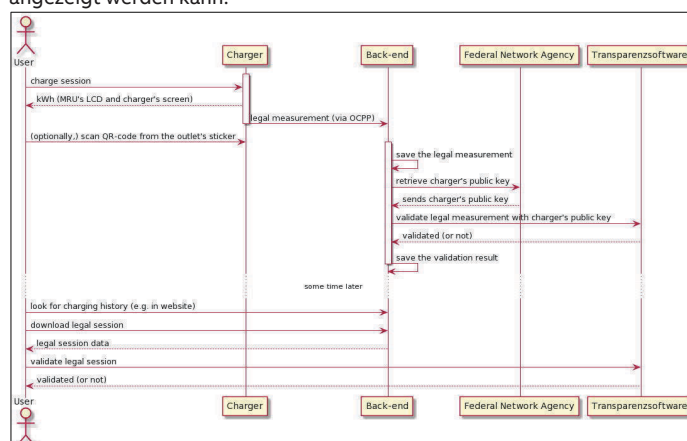

Abbildung 1 – Darstellung der Datensequenz zur Validierung

